



Office: (800) 683-7248

Technical Support: (702) 651-3444

FAX: (702) 651-0214

E-Mail: techsupport@jcm-american.com

Web-Site: www.jcm-american.com

WBA[®] Series

World Bill Acceptor

(WBA-1x/2x -SS & SS2)

Operation and Maintenance Manual
(Revision 1)

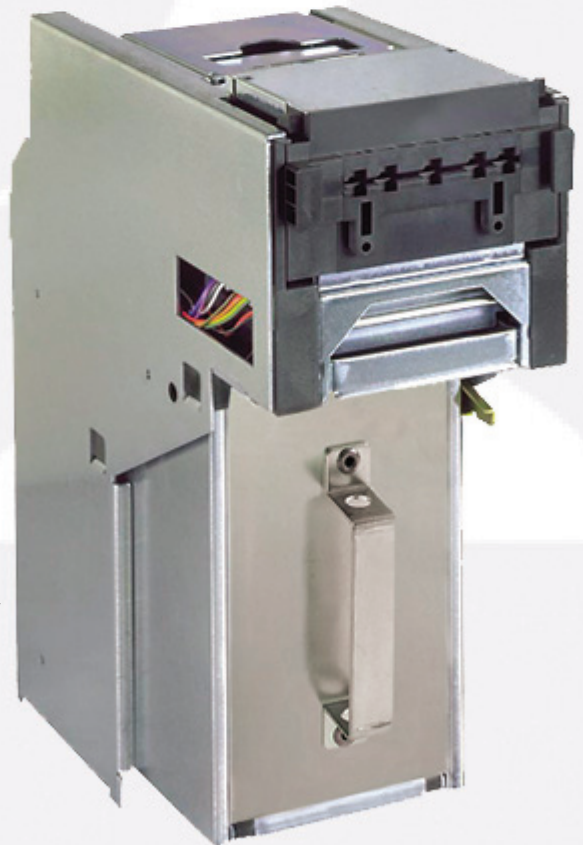

JCM Part No. 960-000076R_Rev. 1



JCM is a registered trademark of JCM American Corporation. All other product names mentioned herein may be registered trademarks or trademarks of their respective companies. Furthermore, TM, ® and © are not always mentioned in each case throughout this publication.

WBA[®] 1x/2x-SS & SS2 Series

Table of Contents

TOC	Page
1 GENERAL INFORMATION	1-1
Model Number Specifications	1-2
Precautions	1-2
User Cautions	1-2
Component Names	1-3
Specifications	1-4
Technical Specifications	1-4
Environmental Specifications	1-4
Electrical Specifications	1-4
Structural Specifications	1-4
System Configuration	1-5
Primary Features	1-5
Standard Unit Dimensions	1-6
Country Codes	1-7
2 INSTALLATION/OPERATION	2-1
Installation	2-1
Changing Bill Guides	2-1
Input/Output Circuits	2-2
Connector Pin Assignments	2-3
Cable Interconnection	2-5
DIP Switch Configurations	2-6
WBA-1X and WBA-2X Head Sensor Lens Differences	2-6
Retrieving Bills	2-7
Clearing a Bill Jam	2-7
Cleaning/Preventive Maintenance	2-8
Available Cleaning Card	2-8
Card Features	2-8
Directions For Use	2-8
ID-003 Standard Interface Operational Flowchart	2-9
3 COMMUNICATIONS	3-1
4 DISASSEMBLY/REASSEMBLY	4-1
Tool Requirements	4-1
Primary Unit Disassembly	4-1
Acceptor Unit Disassembly	4-2
Upper Sensor Circuit Board Removal	4-2
Lower Sensor Circuit Board Removal	4-2
Belt Tension Assembly Removal	4-3
Transport Unit Disassembly	4-3
Transport CPU Circuit Board Removal	4-3
Stacker Encoder Sensor Board Removal	4-4
Stacker Motor Removal	4-5
Transport Encoder Sensor Board Removal	4-5
Transport Drive Motor Removal	4-5
Entrance Lever Sensor Board Removal	4-5
Solenoid Lever Assembly Removal	4-6

Table of Contents

Continued

	Page
Solenoid Lever Sensor Board Removal.....	4-6
Solenoid Lever Assembly Removal.....	4-6
Feed-Out Sensor Assembly Removal.....	4-7
Feed-Out Sensor Assembly Disassembly.....	4-7
Upper Timing Belt Removal.....	4-7
Home Position Sensor Board Removal.....	4-7
Upper Timing Belt Removal Continuation.....	4-8
Lower Timing Belt Removal.....	4-8
Cash Box Disassembly.....	4-9
Pusher Mechanism Removal.....	4-9
Pusher Mechanism Cover Removal.....	4-9
Pusher Mechanism Timing Belt Removal.....	4-9
5 WIRING DIAGRAMS.....	5-1
WBA Primary Components Diagram.....	5-1
WBA-14-SS3B System Wiring Diagram.....	5-3
WBA-15-SS3B System Wiring Diagram.....	5-4
WBA-24-SS3B System Wiring Diagram.....	5-5
WBA-25-SS3B System Wiring Diagram.....	5-6
6 CALIBRATION AND TESTING.....	6-1
Workbench Tool Requirements.....	6-1
Software Download Preparation.....	6-1
Software Downloading Procedure.....	6-2
Program Installation.....	6-2
Calibration Procedure.....	6-2
Calibration Error Messages.....	6-6
Sensor Signal and Name Conversions.....	6-6
Flash Memory Download Procedure.....	6-6
When To Download.....	6-6
7 EXPLODED VIEWS AND PARTS LISTS.....	7-1
Entire WBA Unit View and Parts.....	7-1
Entire WBA Unit Parts List.....	7-2
WBA 12/13 Acceptor Head Exploded Views.....	7-3
WBA 22/23/24/25 Acceptor Head Exploded View.....	7-4
WBA 12/13 & 22/23/24/25 Acceptor Head Collective Parts List.....	7-5
WBA Transport Unit Exploded Views (Continued).....	7-7
WBA Transport Unit Exploded Views (Continued).....	7-8
WBA Transport Unit Exploded Views (Continued).....	7-9
WBA Frame Unit Exploded View.....	7-15
WBA Cash Box Unit Exploded View.....	7-17
WBA Cash Box Unit Exploded View (Continued).....	7-18
8 INDEX.....	8-1
A TROUBLESHOOTING.....	A-1
Introduction.....	A-1
Troubleshooting Overview.....	A-1
Fault Table Listings.....	A-1
Performance Tests.....	A-4
Choosing and Selecting Operational Tests.....	A-4

Table of Contents

Continued

	Page
Auto Calibration Mode	A-4
Calibration Error Table.....	A-4
Diagnostic Test Mode	A-5
Functional Tests	A-5
Head Sensor Test (PH06)	A-5
Head Sensor Test DIP Switch Settings	A-6
Head Sensor Locations	A-6
Transport Sensor Test (PH07)	A-7
Transport Sensor Test	A-7
Transport Sensor Locations	A-8
Sensor, Circuit Board and Motor Locations	A-8
Bill Acceptance Test	A-9
Bill Acceptance Test Modes	A-9
Bill Identification in Bill Acceptance	A-9
Forced Download Mode	A-9
DT-004 Downloading	A-9
DT-104 Downloading	A-10
PC Downloading.....	A-10
Abnormal Error Code Table	A-11
Table A-10 lists the WBA-1X/2X Abnormal Operation Codes.	A-11
Test Mode 4 Only Error Table	A-11
Table A-11 lists the WBA-1X/2X Abnormal Operation Codes.	A-11
Return Code Error Table	A-12
B GLOSSARY	B-1

THIS PAGE INTENTIONALLY LEFT BLANK

WBA® 1x/2x-SS & SS2 Series

List of Figures

LOF		Page
Figure 1-1	World Bill Acceptor WBA-1x-SS).....	1-1
Figure 1-2	Precautionary Symbols.....	1-2
Figure 1-3	World Bill Acceptor (WBA) Major Component Parts.....	1-3
Figure 1-4	WBA System Configuration	1-5
Figure 1-5	WBA Bill Guide Interchangeability	1-5
Figure 1-6	WBA Easy Bill Retrieval Feature	1-5
Figure 1-7	Bill Acceptor WBA-1x-SS Complete Unit Dimensions Diagram	1-6
Figure 2-1	Right Side Panel Dip Switch Block.....	2-1
Figure 2-2	Side Mounting Screw Hole Locations.....	2-1
Figure 2-3	Removing Old Bill Guides.....	2-2
Figure 2-4	Installing New Bill Guides	2-2
Figure 2-5	WBA 12, 13, 22 & 23 Input/Output Circuit Diagram	2-2
Figure 2-6	WBA 10, 11, 20 & 21 Input/Output Circuit Diagram	2-2
Figure 2-7	Typical WBA 1X/2X SS Cabling Requirements.....	2-5
Figure 2-8	Typical WBA 1X/2X SS2 Cabling Requirements.....	2-5
Figure 2-9	WBA 1X-SS & 2X-SS Acceptor Head Lens Differences	2-6
Figure 2-10	Removing the WBA Cash Box.....	2-7
Figure 2-11	Retrieving Bills.....	2-7
Figure 2-12	Clearing an Entrance Bill Jam	2-7
Figure 2-13	Clearing a Transport Unit Bill Jam.....	2-7
Figure 2-14	Clearing a Cash Box Inlet Bill Jam	2-8
Figure 2-15	Cleaning the WBA Bill Path	2-8
Figure 2-16	JCM Waffletechnology Cleaning Card.....	2-8
Figure 2-17	WBA Bill Acceptor Operational Flowchart	2-9
Figure 4-1	WBA Acceptor Head Removal	4-1
Figure 4-2	WBA Transport Unit Removal	4-1
Figure 4-3	WBA Unit Cash Box Removal	4-1
Figure 4-4	WBA Acceptor's Upper Sensor Board Cover Removal	4-2
Figure 4-5	WBA Acceptor's Upper Sensor Board Removal.....	4-2
Figure 4-6	WBA Acceptor's Lower Sensor Board Cover Removal	4-2
Figure 4-7	WBA Acceptor's Lower Sensor Board Removal.....	4-2
Figure 4-8	Acceptor Head Drive Gear Removal	4-3
Figure 4-9	Acceptor Head Drive Belt Assembly Removal	4-3
Figure 4-10	Acceptor Head Drive Gear Tension Unit Disassembly.....	4-3
Figure 4-11	WBA 10/11 CPU Board Removal	4-3
Figure 4-12	WBA Transport CPU Board Assembly Removal	4-4
Figure 4-13	WBA 12/13 CPU Board Disconnect	4-4
Figure 4-14	WBA Transport CPU Board Assembly Removal	4-4

List of Figures

Continued

	Page
Figure 4-15	Transport CPU Board Removal..... 4-4
Figure 4-16	Stack Encoder Sensor Board Removal 4-5
Figure 4-17	Transport Stack Motor Removal..... 4-5
Figure 4-18	Transport Encoder Sensor Board Removal..... 4-5
Figure 4-19	Transport Drive Motor Removal 4-5
Figure 4-20	Entrance Lever Sensor Board Removal 4-6
Figure 4-21	Transport Solenoid Cover Removal 4-6
Figure 4-22	Transport Solenoid Lever Sensor Board Removal 4-6
Figure 4-23	Transport Solenoid Lever Assembly Removal 4-6
Figure 4-24	Complete Transport Solenoid Lever Assembly's Disassembly 4-7
Figure 4-25	Transport Feed-Out Sensor Assembly Removal..... 4-7
Figure 4-26	Transport Feed-Out Sensor Disassembly 4-7
Figure 4-27	Transport Upper Timing Belt Drive Gear Removal..... 4-7
Figure 4-28	Transport Home Sensor Board Removal 4-8
Figure 4-29	Transport Timing Belt Removal..... 4-8
Figure 4-30	Complete Transport Timing Belt Shaft Component Disassembly 4-8
Figure 4-31	Lower Timing Belt Access 4-8
Figure 4-32	Lower Timing Belt Removal..... 4-9
Figure 4-33	Pusher Mechanism Removal..... 4-9
Figure 4-34	Pusher Mechanism Cover Removal 4-9
Figure 4-35	Coupling Bracket Handle Removal..... 4-9
Figure 4-36	Pusher Mechanism Gear Removal..... 4-10
Figure 4-37	Pusher Mechanism Belt Removal 4-10
Figure 5-1	World Bill Acceptor (WBA) Primary Components..... 5-1
Figure 5-2	WBA-14-SS3B Bill Acceptor System Wiring Diagram 5-3
Figure 5-3	WBA-15-SS3B Bill Acceptor System Wiring Diagram 5-4
Figure 5-4	WBA-24-SS3B Bill Acceptor System Wiring Diagram 5-5
Figure 5-1	WBA-25-SS3B Bill Acceptor System Wiring Diagram 5-6
Figure 6-1	Required WBA Download Workbench Tools..... 6-1
Figure 6-2	WBA DIP Switch & Port Location 6-2
Figure 6-3	Initial Setup Screen 6-2
Figure 6-4	Head Installed Confirmation 6-2
Figure 6-5	White Paper Calibration Screen 6-2
Figure 6-6	White Calibration Paper Types..... 6-3
Figure 6-7	Inserting White Calibration Paper..... 6-3
Figure 6-8	White Calibration Occurring Screen 6-3
Figure 6-9	Black Paper Calibration Screen..... 6-3
Figure 6-10	Black Calibration Paper Types 6-3
Figure 6-11	Inserting Black Calibration Paper 6-3
Figure 6-12	Black Calibration Occurring Screen..... 6-3

List of Figures Continued

		Page
Figure 6-13	White Re-Calibration Request Screen.....	6-4
Figure 6-14	Remove Calibration Paper Screen.....	6-4
Figure 6-15	Removing Final Calibration Paper.....	6-4
Figure 6-16	Paperless Calibration Screen.....	6-4
Figure 6-17	Magnetic Test Calibration Screen.....	6-4
Figure 6-18	Aligning the MAG Head Calibration Test Board.....	6-4
Figure 6-19	Magnetic Adjust Value Screen.....	6-5
Figure 6-20	Locating the MAG Head Calibration Peak Value Reading.....	6-5
Figure 6-21	Adjusting Magnetic Gain Screen.....	6-5
Figure 6-22	Write Value Prompt Screens.....	6-5
Figure 6-23	Writing Adjustment Data Screen.....	6-5
Figure 6-24	End Calibration Screen.....	6-5
Figure 6-25	Typical Error Message Screen.....	6-6
Figure 7-1	Entire WBA Unit Exploded View.....	7-1
Figure 7-2	WBA 12/13 Acceptor Head Exploded View.....	7-3
Figure 7-3	WBA 22/23/24/25 Acceptor Head Exploded View.....	7-4
Figure 7-4	WBA Transport Unit Exploded View (Part 1).....	7-7
Figure 7-5	WBA Transport Unit Exploded View (Part 2).....	7-8
Figure 7-6	WBA Transport Unit Exploded View (Part 3).....	7-9
Figure 7-7	WBA Frame Unit Exploded View.....	7-15
Figure 7-8	WBA Cash Box Exploded View (Part 1).....	7-17
Figure 7-9	WBA Cash Box Exploded View (Part 2).....	7-18
Figure A-1	WBA 1x Head Sensor Locations.....	A-6
Figure A-2	WBA 2X Head Sensor Locations.....	A-7
Figure A-3	WBA-1X/2X Transport Sensor Locations.....	A-8
Figure A-4	WBA-1X/2X Sensor, Circuit Board and Motor Location Diagram.....	A-8

THIS PAGE INTENTIONALLY LEFT BLANK

WBA[®] 1x/2x-SS & SS2 Series

List of Tables

LOT	Page
Table 1-1 Model Number Specifications	1-2
Table 1-2 WBA-1x-SSx Technical Specification	1-4
Table 1-3 WBA-1x Environmental Specification	1-4
Table 1-4 WBA-1x Electrical Specification	1-4
Table 1-5 WBA-1x Structural Specification	1-4
Table 1-6 Country Code Listings.....	1-7
Table 2-1 Connector CN1 Pin Assignments	2-3
Table 2-2 Connector CN2 Pin Assignments	2-3
Table 2-3 Relay Connector Pin Assignments	2-3
Table 2-4 WBA-10/11,20&21-SS 12 Pin Rear Panel Connector Pin Assignments.....	2-3
Table 2-5 WBA-12/13,22&23-SS2 20 Pin Rear Panel Connector Pin Assignments	2-4
Table 2-6 DIP Switch Settings	2-6
Table 6-1 WBA-1X-SS Validator Sensor Names	6-6
Table 6-2 WBA-2X-SS Validator Sensor Names	6-6
Table 7-1 Entire WBA Unit Parts List.....	7-2
Table 7-2 WBA 12/13&22/23/24/25 Acceptor Head Collective Parts List	7-5
Table 7-3 WBA Transport Unit Collective Parts List	7-11
Table 7-4 WBA Frame Unit Parts List	7-16
Table 7-5 WBA Cash Box Collective Parts List.....	7-19
Table A-1 General Fault Conditions	A-1
Table A-2 Adjustment Fault Conditions	A-3
Table A-3 Communication Fault Conditions	A-3
Table A-4 WBA-1X Calibration Error Indications.....	A-4
Table A-5 WBA-1X/2X Functional Test DIP Switch Settings.....	A-5
Table A-6 WBA-1X/2X Head Sensor Test DIP Switch Setting Chart	A-6
Table A-7 WBA-1X/2X Transport Sensor Test DIP Switch Setting Chart	A-7
Table A-8 WBA-1X/2X Bill Acceptance Test Setting Chart	A-9
Table A-9 WBA-1X/2X Forced Download Mode Chart.....	A-9
Table A-10 WBA-1X/2X Abnormal Operation Code Table	A-11
Table A-11 WBA-1X/2X Test Mode 4 Abnormal Operation Code Table	A-11
Table A-12 WBA-1X/2X Return Error Code Table	A-12

THIS PAGE INTENTIONALLY LEFT BLANK

WBA[®] Series

World Bill Acceptor (WBA[®]-1x/2x-SS & SS2)

Section 1



1 GENERAL INFORMATION

This section provides a general overview of the World Bill Acceptor Series (WBA-1x-SS) pictured in Figure 1-1. This first section is designed to help you navigate through the manual with ease and provides the following information:

- Model/Type Number Specifications
- Precautions
- Component Names
- System Configuration
- Specifications
- Primary Features
- Complete Unit Dimensions
- Unit Dimensions with WBA Faceplate
- Unit Dimensions with ICB

- Standard Cash Box Dimensions
- Country Codes

In order to make operation of this device easier and make navigation within this manual simpler, the following illustrations were used within the text:

- **Safety Instructions**, which need to be observed in order to protect the operators and equipment, have been written in bold text and have been given the pictographs: 
- **Special Notes**, which effect the use of the Bill Acceptor, have been written in *italic* text and have been given the pictograph: 
- **Steps**, requiring the operator to perform specific actions are given sequential numbers (1., 2., 3., etc.)

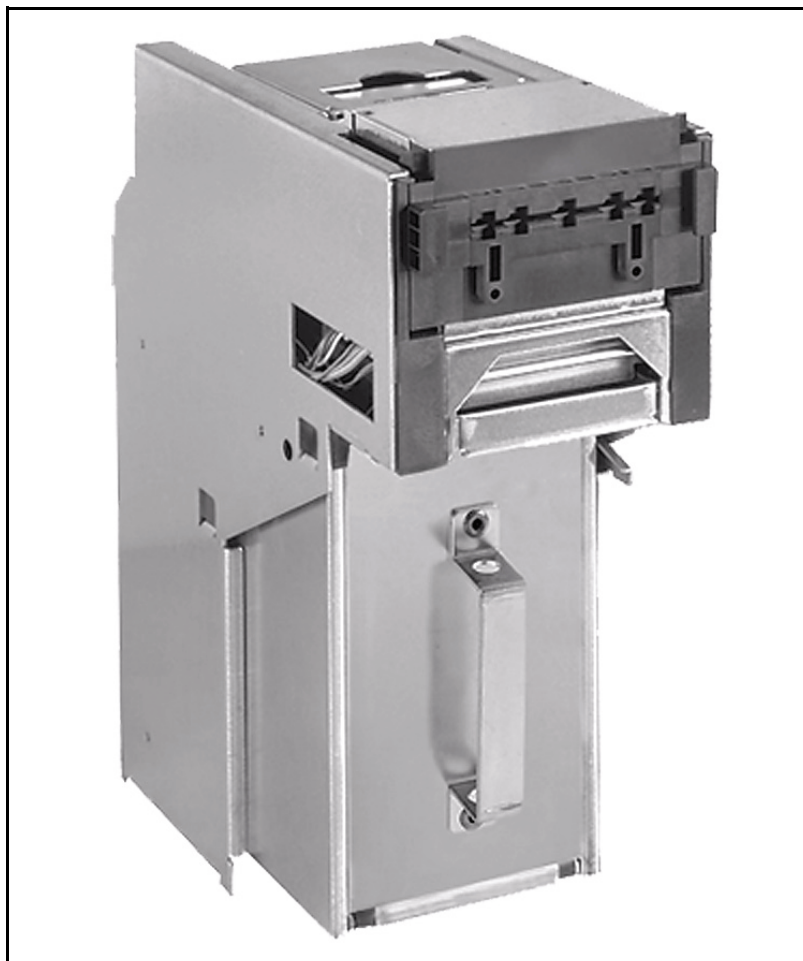

Figure 1-1 World Bill Acceptor WBA-1x-SS)

Model Number Specifications

Table 1-1 Model Number Specifications

No	Model: WBA - ** - SS* - ***(*) - *** - **																																																						
	No	(1)(2)	(3)	(4)(5)	(6,7,8)	(9)																																																	
(1)	Acceptor head type 1. 1x Head (magnetic sensors enhanced) 2. 2x Head (optical sensors enhanced)																																																						
(2)	CPU board type 0. 1Mbit Flash ROM 2&4. 4Mbit Flash ROM 1. 1Mbit EPROM 3&5. 4Mbit EPROM																																																						
(3)	Box type SS = SS Down Stacker (80mm width) SS2 = SS Down Stacker (82mm width for Euro Banknotes)																																																						
(4)	Country Code Refer to Table 1-6 on page 7																																																						
(5)	Denominations accepted Relative to the Country Code programmed (Euro Examples)																																																						
	<table border="1"> <thead> <tr> <th>Denomination \ Country Code</th> <th>€5</th> <th>€10</th> <th>€20</th> <th>€50</th> <th>€100</th> <th>€200</th> <th>€500</th> </tr> </thead> <tbody> <tr> <td>EUR1</td> <td>X</td> <td>X</td> <td>X</td> <td></td> <td></td> <td></td> <td></td> </tr> <tr> <td>EUR2</td> <td>X</td> <td>X</td> <td>X</td> <td>X</td> <td></td> <td></td> <td></td> </tr> <tr> <td>EUR3</td> <td>X</td> <td>X</td> <td>X</td> <td>X</td> <td>X</td> <td></td> <td></td> </tr> <tr> <td>EUR4</td> <td>X</td> <td>X</td> <td>X</td> <td>X</td> <td>X</td> <td>X</td> <td></td> </tr> <tr> <td>EUR5</td> <td>X</td> <td>X</td> <td>X</td> <td>X</td> <td>X</td> <td>X</td> <td>X</td> </tr> </tbody> </table>							Denomination \ Country Code	€5	€10	€20	€50	€100	€200	€500	EUR1	X	X	X					EUR2	X	X	X	X				EUR3	X	X	X	X	X			EUR4	X	X	X	X	X	X		EUR5	X	X	X	X	X	X	X
Denomination \ Country Code	€5	€10	€20	€50	€100	€200	€500																																																
EUR1	X	X	X																																																				
EUR2	X	X	X	X																																																			
EUR3	X	X	X	X	X																																																		
EUR4	X	X	X	X	X	X																																																	
EUR5	X	X	X	X	X	X	X																																																
(6)	Box capacity 4 = 400 note capacity 5 = 500 note capacity (standard) A = 1000 note capacity																																																						
(7)	Faceplate* 0 = Without Faceplate (standard) 1 = With JCM standard WBA Faceplate (85mm wide)																																																						
(8)	Guide Width 1 = 66mm 4 = 80mm 2 = 70mm 5 = 82mm 3 = 75mm																																																						
(9)	External Interface† 01 = ID001: Parallel Interface 02 = ID002: Pulse Interface 03 = ID003: Bidirectional Serial Interface (standard) 44 = ID044/045: Serial & Pulse Interface 0A2 = ID-0A2: Serial & Pulse Selectable Interface																																																						

*. Contact your JCM Sales Representative for information concerning Faceplates, and other options available.

†. Contact JCM for other Interface requirements.

Precautions

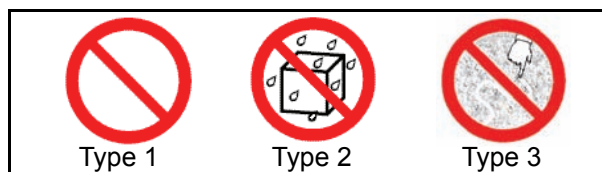

Figure 1-2 Precautionary Symbols

The Figure 1-2 symbols are defined as follows:

- (Type 1)** Do not insert a torn, folded, or wet bill, as this action may cause a bill jam inside the unit.
- (Type 2)** Do not expose the unit to water. The unit contains several precision electronic devices which can be damaged if water or any liquid is sprayed or spilled into the unit.
- (Type 3)** Do not install the unit into a dusty environment. Dust may affect and degrade the sensor's performance.

Do NOT carry the WBA unit by the Cash Box handle, it can release and drop the unit to the ground causing housing damage.

User Cautions

- Be sure to turn the power off before plugging or unplugging connectors.
- Firmly close the unit's Transport path before applying power.
- When closing the unit, ensure all service door locks click into place. Make sure to open and close the unit's bill path access ports gently, and take care that no dust or other foreign objects enter when opening the guide area.
- Do not allow inventory stock to endure high temperature, high humidity or a dusty environment.
- Do not throw the unit or allow it to fall to the ground. Improper handling may cause personal injury and/or damage to the equipment.
- If the bill validator is dirty due to dust, foreign objects, or other such debris adhering to it, the bill acceptance rate will degrade. Use a soft, lint-free cloth and a mild non-abrasive soap and water solution to clean dust and debris from the bill path.

Under no circumstances allow the cloth to be wet enough to allow excess fluid to run into the device; internal printed circuit boards may be damaged. Do not use any alcohol, solvents or scouring agents which can attack the plastic surfaces of the device.

A new JCM authorized Waffletechnology Cleaning Card is now available. Refer to “Cleaning/Preventive Maintenance” on page 8 of Section 2 of this manual for

further information concerning its availability and use.

7. Inserting worn or damaged bills may also cause a bill jam.

Component Names

Figure 1-3 illustrates the WBA primary component parts and their relative locations.

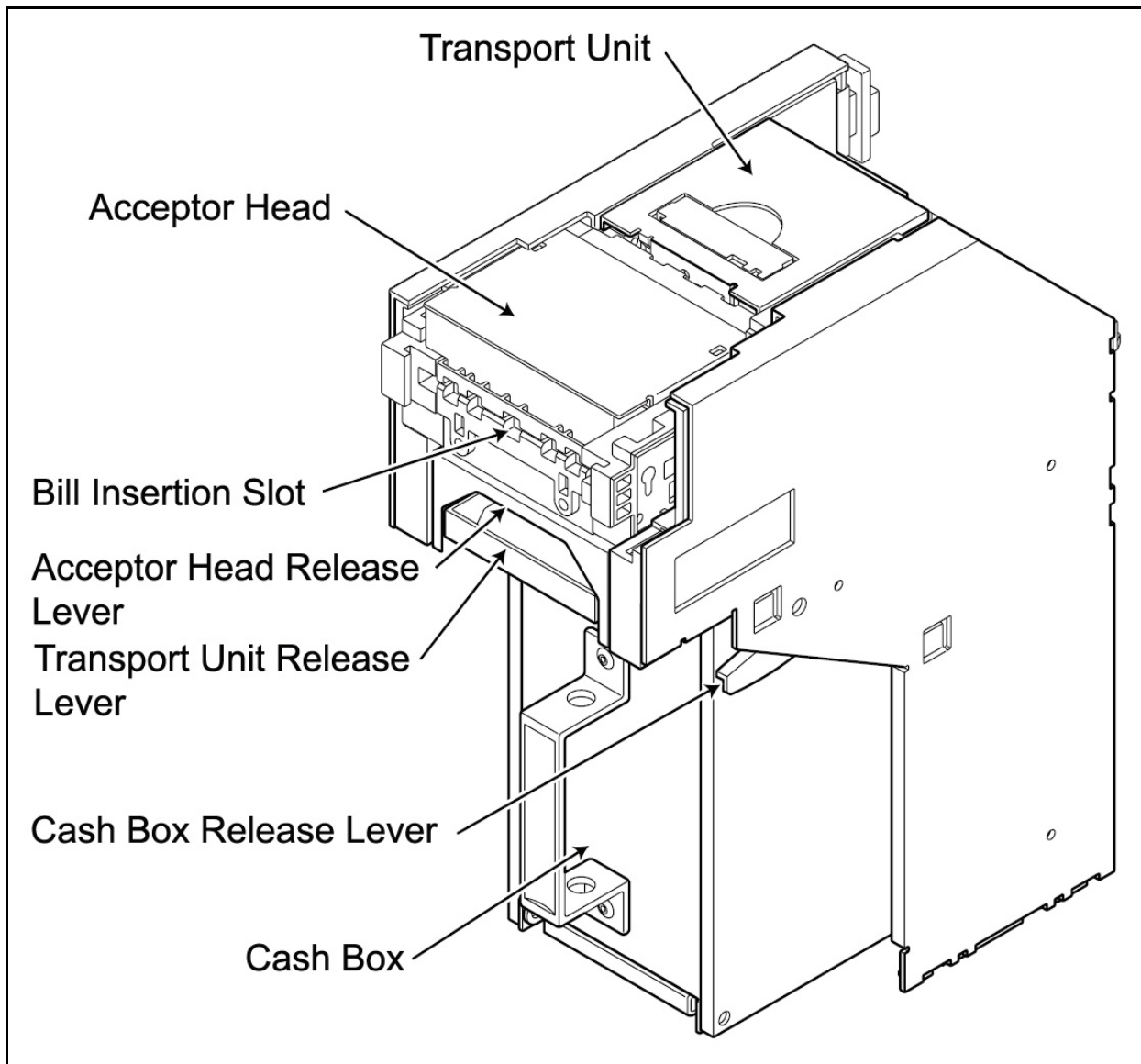

Figure 1-3 World Bill Acceptor (WBA) Major Component Parts

Specifications

Technical Specifications

Table 1-2 WBA-1x-SSx Technical Specification

Accepted Denominations:	Refer to the software specifications of each unit.
Bill Insertion:	Refer to the software specifications of each unit.
Acceptance Rate:	90% or greater (Including the 1st return and 2nd acceptance.* *Note: The following bills types are excluded: a) Bills with excessive or poor magnetism or unclear graphics b) Double (dual) notes c) Worn, dirty, wet, torn or excessively wrinkled bills d) Bills having folded corners or edges e) Bills having the wrong cut dimensions or printing displacement f) When security measures against counterfeiting are implemented, the software may not fulfill the specified acceptance rate level.
Validation Time:	Within 2 seconds (Time until the output of the vend signal).
Bill Types Accepted:	Width: 2.44 – 3.35 in. (62 – 85mm), Length: 4.72 – 6.5 in. (120 – 165mm [up to 6.7 in. (170mm) with a Steel Cash Box])
Insertion Direction:	Refer to Software Specifications relative to bills being used
Processing Speed:	Approximately 2 seconds (from bill insertion to vend signal output) Approximately 5 seconds (from bill insertion to completion of stacking)
Escrow:	One bill or one barcode coupon
Cash Box Type:	Security (lockable) box*
Cash Box Capacity:	Average 500 bills (Coupons)
Interface:	ID-003 bi-directional Serial Interface

*. The lock to be installed by the user (the catch is supplied with the unit.)

Environmental Specifications

Table 1-3 WBA-1x Environmental Specification

Operating Temperature:	32°F to ~ 113°F (0°C to ~ +45°C)
Storage Temperature:	- 4°F to ~ 140°F (-20°C to ~ +60°C)
Relative Operating Humidity:	30% to ~ 80% RH (non-condensed)
Relative Storage Humidity:	30% to ~ 86% RH (non-condensed)
Visible Light Sensitivity:	Avoid Direct Sunlight Contact
Installation:	Indoors Only

Electrical Specifications

Table 1-4 WBA-1x Electrical Specification

Supply Voltage:	12VDC \pm 5% (NOTE: Use a power supply with a 2.5A or more capability).
Current Consumption:	Standby = 2.8VA Operation = 14VA (Max = 24VA)

Structural Specifications

Table 1-5 WBA-1x Structural Specification

Unit Weight:	Approximately 10.582 lbs (~4.8kg)
Cash Box Weight	Approximately 3.307 lbs (~1.5kg empty)
Mounting:	Horizontal
Outer Dimensions:	11.96 in (303.8mm) High x 8.86 in (225mm) Deep x 4.49 in (114mm) Wide

System Configuration

Figure 1-4 illustrates a typical WBA system configuration.

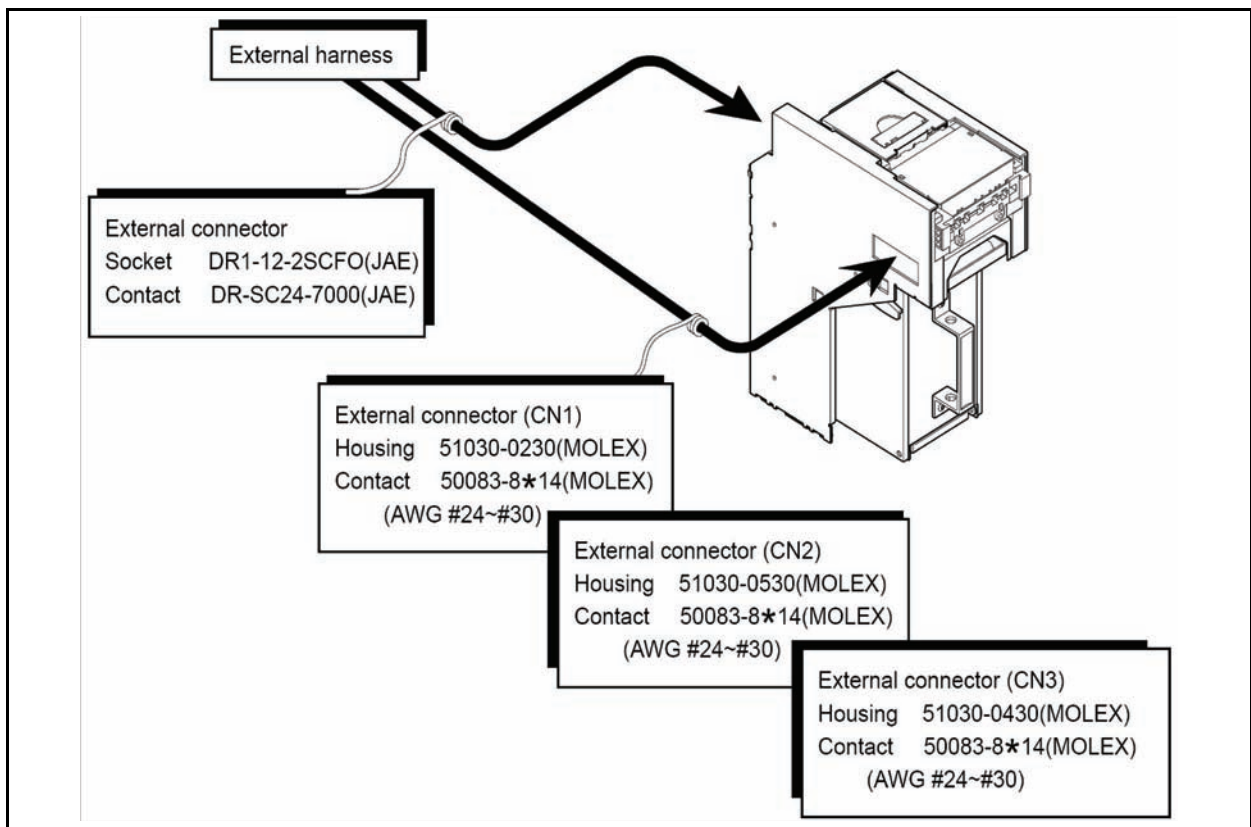

Figure 1-4 WBA System Configuration

Primary Features

The WBA Series of Bill Validators contains the following primary features:

- **Interchangeable Bill Guides**

- Ability to read a wide range of bill sizes. Four types of bill guides are available for the WBA. Switching the bill guides allows the unit to read bills ranging from 62mm to 82mm wide.
- The length of bills read are from 125mm t 170mm (See Figure 1-5).

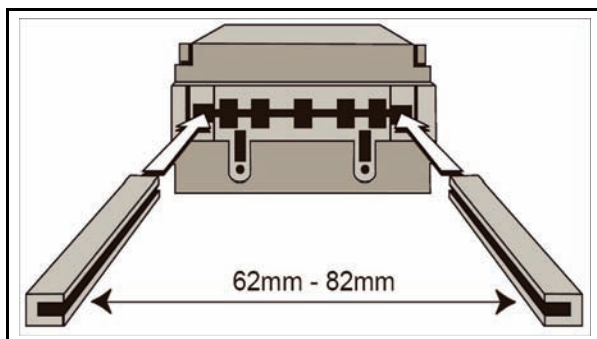

Figure 1-5 WBA Bill Guide Interchangeability

- **DIP Switch Programmable Bill Acceptance**

- DIP switch settings to accept/reject bills
- Up to 7 denominations acceptable.
- Accept or Reject of each denomination is DIP Switch selectable.

- **Easy Bill Retrieval**

- The cash box can be detached from the main unit to withdraw deposited bills.
- The machine can be equipped with a lock for higher security. Each SS and SS2 cash box stores up to 500 bills (See Figure 1-6).

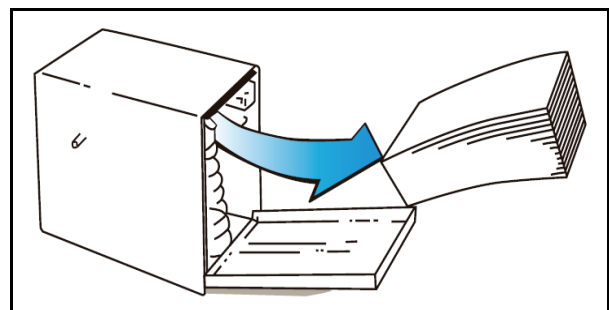
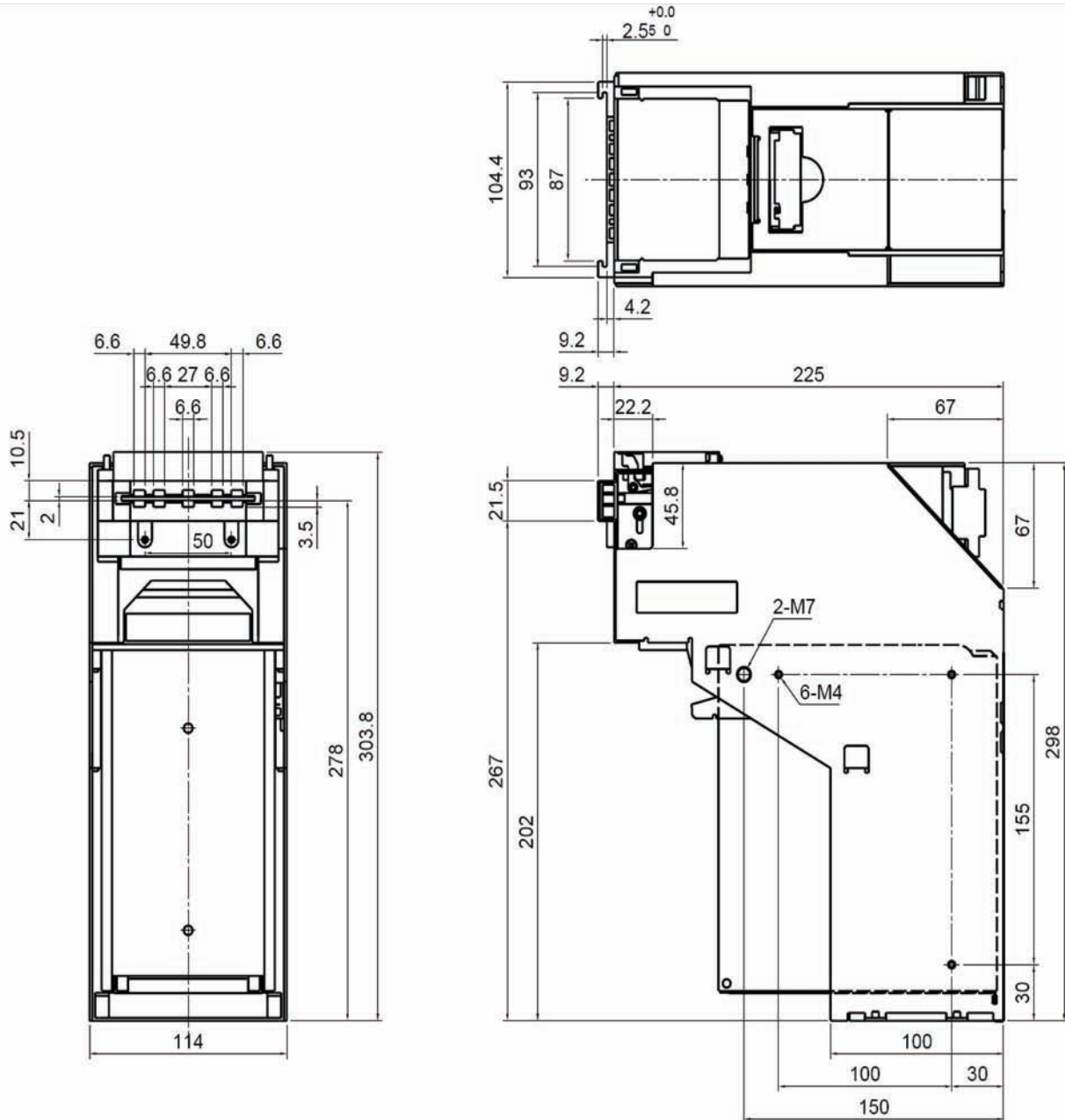

Figure 1-6 WBA Easy Bill Retrieval Feature

Standard Unit Dimensions

Figure 1-7 illustrates the WBA-1x-SS standard unit dimensions.



NOTE: All Units are in Millimeters.

Figure 1-7 Bill Acceptor WBA-1x-SS Complete Unit Dimensions Diagram

Country Codes**Table 1-6** Country Code Listings

Country	Country Code
Antilles	ANT
Argentina	ARG
Australia	AUS
Austria	AUT
Austria	AUT4
Barbados	BRB
Belgium	BEL
Botswana	BWA
Brazil	BRA
Bulgaria	BGR
Canada	CAN
Canada	CAN
Chile	CHL
China	CHN
Colombia	COL
Costa Rica	CRI
Croatia	HRV
Cyprus	CYP
Czech Republic	CZE
Denmark	DNK
Estonia	ESTE
Estonia	EST2
European Union	EUR
Finland	FIN
France	FRA
Germany	DEU
Germany	DEU1
Germany	DEU2
Germany/Sweden	DEU/SWE
Great Britain (England)	GBR
Great Britain (England)	GBR-B
Great Britain/Gibraltar	GBR/GBI
Great Britain/Isle Of Man	GBR/MAN
Greece	GRC
Greece	GRC-B
Guatemala	MGT
Honduras	HND
Hong Kong	HKG
Hungary	HUN

Table 1-6 Country Code Listings (Continued)

Country	Country Code
Iceland	ISL
India	IND
Israel	ISR
Italy	ITA
Italy	ITA8
Italy	ITA9
Japan	JPN
Kazakhstan	KAZ
Kazakhstan	KAZ1
Latvia	LVA
Lithuania	LTU
Malaysia	MYS
Malaysia	MYS1
Malta	MLT
Mauritius	MUS
Mexico	MEX
Moldova	MDA
Morocco	MAR
Namibia	NAM
Netherlands	NLD
Netherlands	NLD-B
New Zealand	NZL
New Zealand	NZL1
New Zealand	NZL-B
North Ireland	NIRL
Norway	NOR
Norway	NOR1
Peru	PER
Peru	PER1
Philippines	PHL
Philippines	PHL1
Poland	POL
Poland	POL1
Poland	POL1-B
Portugal	PRT
Qatar	QAT
Republic Of Ireland	IRL
Republic Of Korea	KOR
Republic Of Korea	KOR-B
Romania	ROM

Table 1-6 Country Code Listings (Continued)

Country	Country Code
Russia	RUS
Russia	RUS-B
Saudi Arabia	SAU
Singapore	SGP
Singapore	SGP-B
Slovakia	SVK
Slovenia	SVN
South Africa	ZAF
Spain	ESP
Sri Lanka	LKA
Sweden	SWE
Switzerland	CHE
Switzerland	CHE3
Switzerland	CHE-B
Taiwan (Republic Of China)	TWN
Tanzania	TZA
Thailand	THA
Trinidad & Tobago	TTO
Ukraine	UKR
Ukraine	UKR1
United Arab Emirates	ARE
United States	USA
Uruguay	URY
Uruguay	URY1
Venezuela	VEN
Venezuela	VEN1
Venezuela	VEN2
Venezuela	VEN-B

These Country Codes conform to the ISO 3166 Country Code list definitions.

WBA[®] Series

World Bill Acceptor (WBA[®]-1x/2x-SS & SS2)

Section 2

2 INSTALLATION/OPERATION

This section provides installation and operation instructions for the World Bill Acceptor Series (WBA). The information within contains the following features:

- Installation
- Lock Installation
- DIP Switch Configurations
- Connector Pin Assignments
- Jumper Configurations
- Retrieving Bills
- Clearing a Bill Jam
- Cleaning/Preventive Maintenance
- Operational Flowchart
- Interface Circuit Schematic.

Installation

Perform the following steps to install the WBA unit:

1. Remove power from host machine.
2. Set WBA DIP Switches if required (See Figure 2-1). The initial setting is ALL switches OFF to enable all denominations.



NOTE: Verify the software in the WBA before reinstalling it. The DIP Switch settings are determined by the software. See the separately provided software specifications for the DIP Switch settings for your application.

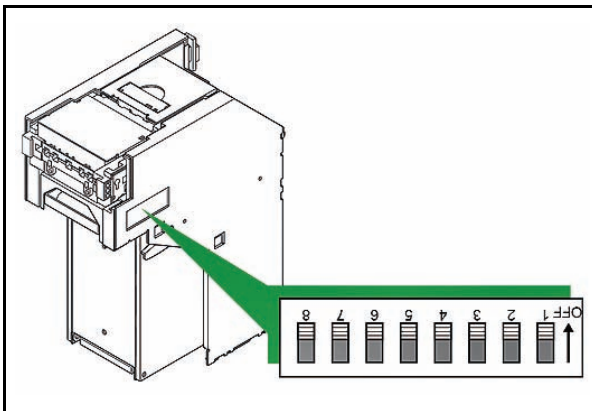
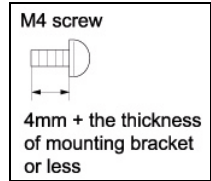

Figure 2-1 Right Side Panel Dip Switch Block

3. Install the WBA into the host machine using Round Head M4 mounting screws. There are three (3) mounting holes located on each side of the frame (See Figure 2-4).



NOTE: The maximum length of M4 Round Head Screws should be 4mm plus the thickness of the cabinet or mounting bracket.



Example: If the WBA is mounted on a bracket that is 2mm thick, the M4 screws should be no more than 6mm in length.

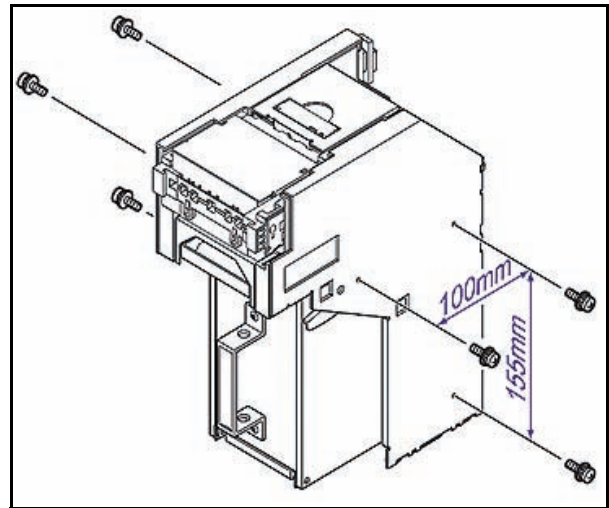

Figure 2-2 Side Mounting Screw Hole Locations

Changing Bill Guides

Unless your WBA had been used with previous software installed, the correct bill guides should be installed in the acceptor unit.

Each software package has designated bill guide types assigned to it (i.e., USA = 66mm width = Type 1 Bill Guide, EUR5 = 82mm width = Type 5 Bill Guide).

Refer to the software specification for your specific application to find which bill guide should exist.

To remove the bill guides proceed as follows:

1. First remove the acceptor head from the main unit, then
2. Push the bill guides out from the back of the Acceptor Head section with a Flat-blade Screwdriver (See Figure 2-3).

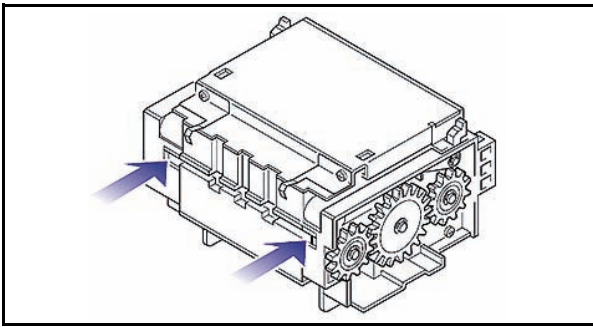

Figure 2-3 Removing Old Bill Guides

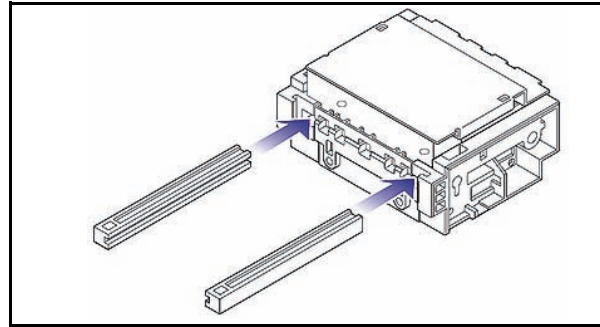

Figure 2-4 Installing New Bill Guides

3. To install the new bill guides, push the guides back into the Acceptor Head slot from the front until you hear a click (See Figure 2-4). Be sure to push the guides into the assembly in the correct direction.

Input/Output Circuits

1. Figure 2-5 and Figure 2-6 illustrate the various WBA Input/Output Circuit Diagrams.

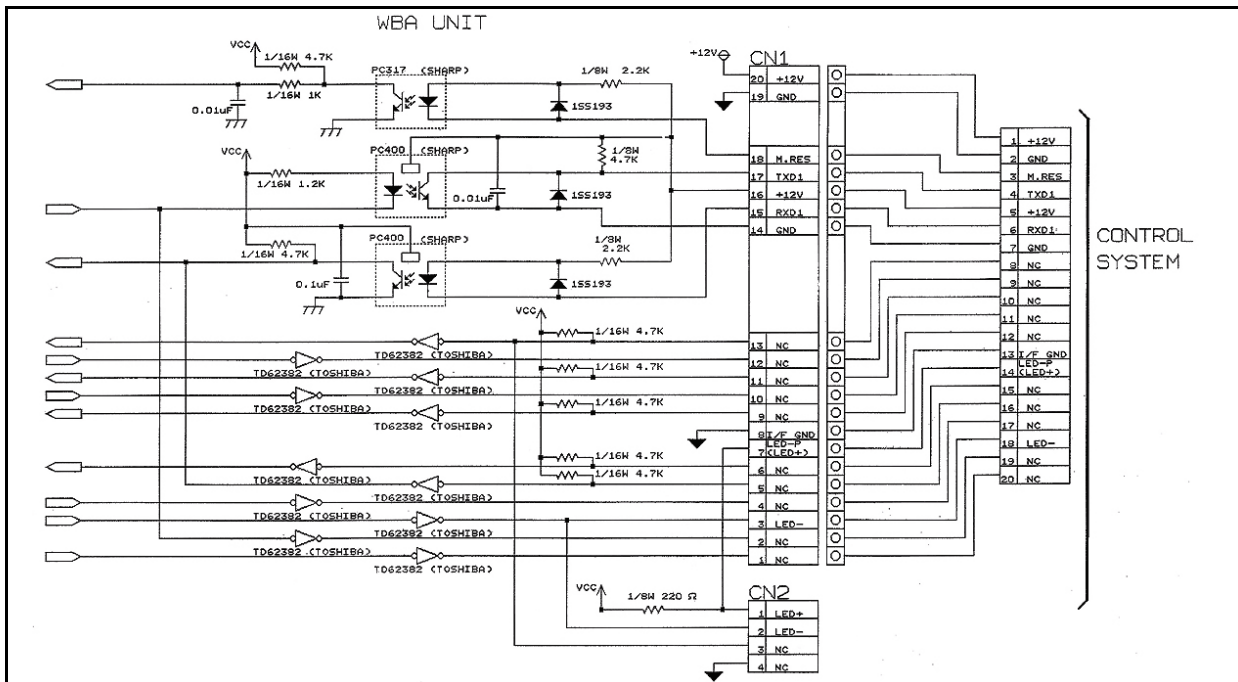

Figure 2-5 WBA 12, 13, 22 & 23 Input/Output Circuit Diagram

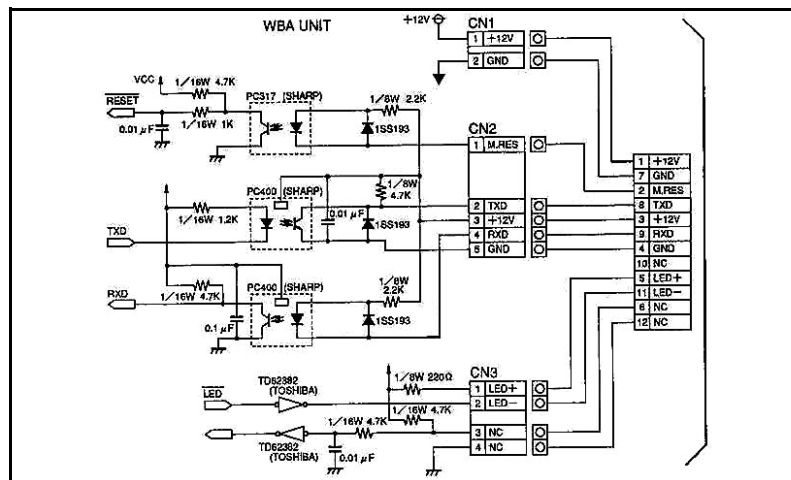



Figure 2-6 WBA 10, 11, 20 & 21 Input/Output Circuit Diagram

Connector Pin Assignments

Table 2-1 through Table 2-4 list the various WBA Connector pin assignments.

Tables 2-1 through Table 2-3 list the WBA-1X/2X-SS & SS2 Circuit Board Connector pin assignments.

Table 2-1 Connector CN1 Pin Assignments

Connector CN1		
		
Header: 53103-0230 (Japan Molex) Contact Type: 50083-8*14 (Japan Molex) Housing: 51030-0230 (Japan Molex) Recommended Wire: UL1007 AWG#24 to 30		
Switch No.	Signal Name	Function
1	+12 V	+12 V DC Power Supply
2	Gnd	Ground

Tables 2-4 and 2-5 respectively lists the WBA-1X/2X-SS & SS2 Rear Panel Connector pin assignment.

Table 2-2 Connector CN2 Pin Assignments

Connector CN2		
		
Header: 53103-0530 (Japan Molex) Contact Type: 50083-8*14 (Japan Molex) Housing: 51030-0530 (Japan Molex) Recommended Wire: UL1007 AWG#24 to 30		
Pin No.	Signal Name	Function
1	M. RES	Acceptor Reset Signal
2	T _{XD}	Data transmission
3	+12V	+12V DC Interface Power
4	R _{XD}	Data Reception
5	GND	Signal Ground

Table 2-3 Relay Connector Pin Assignments

Connector CN3		
		
Header: 53103-0430 (Japan Molex) Contact Type: 50083-8*14 (Japan Molex) Housing: 51030-0430 (Japan Molex) Recommended Wire: UL1007 AWG#24 to 30		
Pin No.	Signal Name	Function
1	LED +	LED drive (anode)
2	LED -	LED drive (cathode)
3	NC	Reserved (No Connection)
4	NC	Reserved (No Connection)

Table 2-4 WBA-10/11,20&21-SS 12 Pin Rear Panel Connector Pin Assignments

WBA-10/11,20&21-SS Rear Panel Connector			
			
Socket Jack: DR1-12-2SCFO (JAE) Contact Type: DR-SC24-7000 (JAE) Socket Plug: DR1-12-2PCFO (JAE) Contact Type: DR-SP24-7000 (JAE)			
Pin No.	Signal Name [*]	I/O [†]	Function
1	+12V		+12V DC Power Supply
2	GROUND (Power)		0V DC Ground Plain
3	M. RES	In	Acceptor Reset Signal
4	TXD	Out	Data Transmission from WBA
5	+12V I/F		+12V DC Interface Power
6	RXD	In	Data Reception into WBA
7	GND I/F		Zero (0) Volt DC Interface Power
8	NC		Reserved (No Connection)
9	LED +		LED drive (anode)
10	LED -		LED drive (cathode)
11	NC		Reserved (No Connection)
12	NC		Reserved (No Connection)

*. I/O (input/output) is the terminal viewed from Bill Acceptor's side.

†. Signal name, I/O, and function without parenthesis are for ID-003 interface.

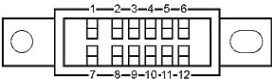
Table 2-5 WBA-12/13,22&23-SS2 20 Pin Rear Panel Connector Pin Assignments

WBA-12/13,22&23-SS2 Rear Panel Connector

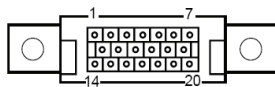

Socket Jack: DRA-20PC-FO (JAE)
 Contact Type: DO2-22-26P -10000 (JAE)
 Socket Plug: DRA-20SC-FO (JAE)
 Contact Type: DO2-22-26S -10000 (JAE)

Pin No.	Signal Name*	I/O†	Function
1	+12V POWER		+12V DC power
2	GROUND (Power)		0V DC Ground Plain
3	M. RES	In	Bill Acceptor master reset signal line
4	TXD	Out	Transmit serial data signal output line from WBA
5	+12V DC I/F		+12V DC Interface Power
6	RXD	In	Receive serial data signal input line into WBA
7	GND I/F		Zero (0) Volt DC Interface power
8	NC		Reserved (No Connection)
9	NC		Reserved (No Connection)
10	NC		Reserved (No Connection)
11	NC		Reserved (No Connection)
12	NC		Reserved (No Connection)
13	GND		Ground
14	LED+		LED Drive (anode)
15	NC		Reserved (No Connection)
16	NC		Reserved (No Connection)
17	NC		Reserved (No Connection)
18	LED-		LED Drive (cathode)
19	NC		Reserved (No Connection)
20	NC		Reserved (No Connection)

*. I/O (input/output) is the terminal viewed from Bill Acceptor's side.

†. Signal name, I/O, and function without parenthesis are for ID-003 interface.

Cable Interconnection

Figure 2-7 illustrates the typical cabling requirements between the Host Machine and a WBA 1X/2X SS Bill Validator.

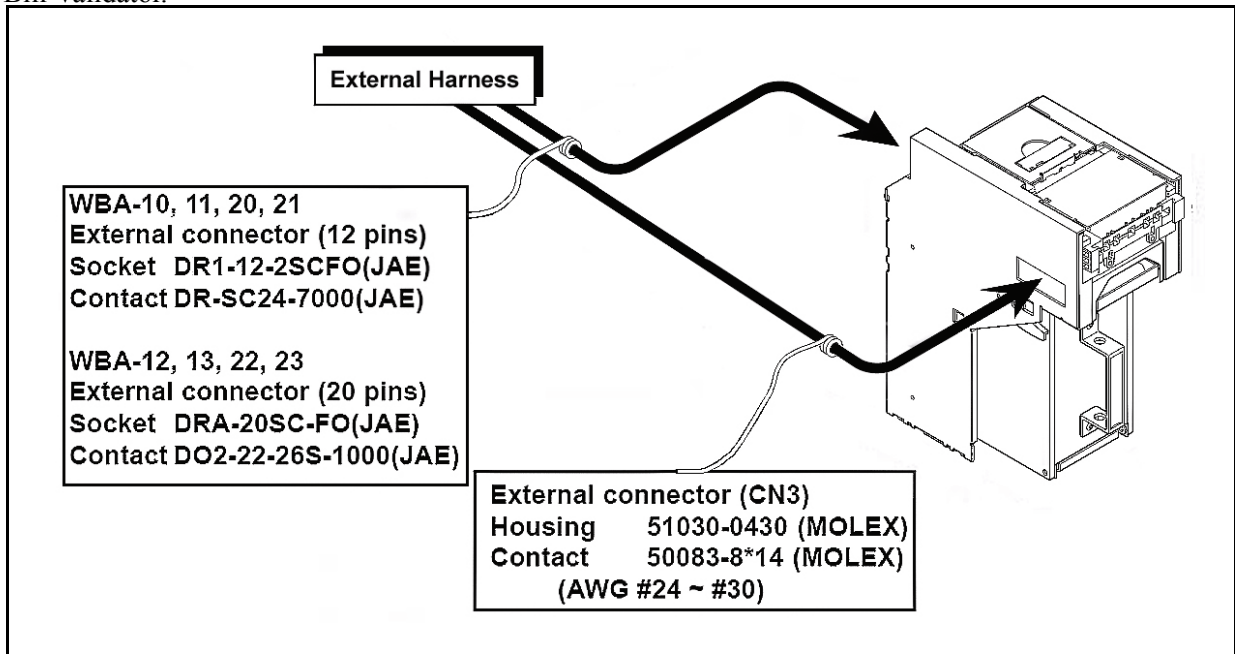

Figure 2-7 Typical WBA 1X/2X SS Cabling Requirements

Figure 2-8 illustrates the typical cabling requirements between the Host Machine and a 1X/2X SS2 Bill

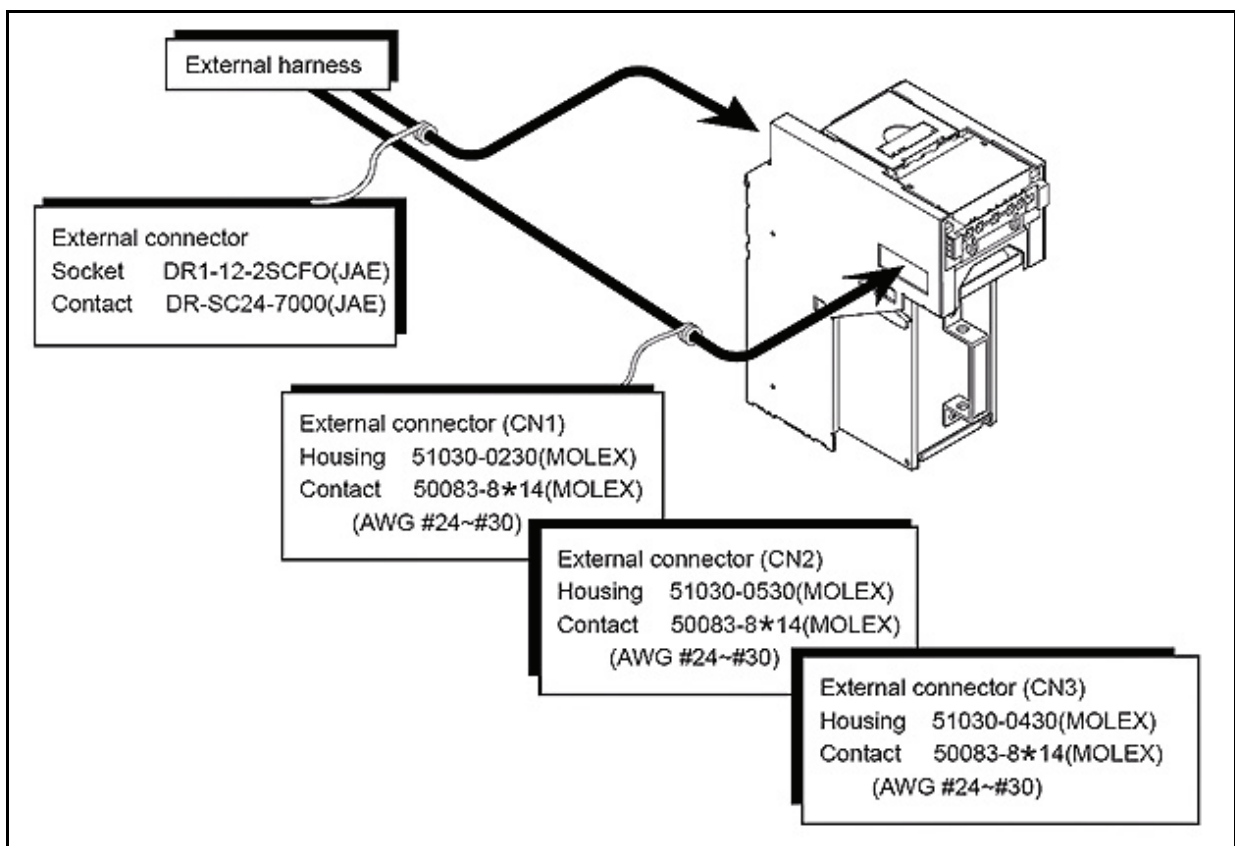

Figure 2-8 Typical WBA 1X/2X SS2 Cabling Requirements

DIP Switch Configurations

Table 2-6 lists the default DIP Switch configurations for the WBA Right Side panel DIP Switch Block.

Table 2-6 DIP Switch Settings

WBA Right Side Panel Switches		
		
Default Setting = ALL Switches are OFF		
Switch No.	Switch ON	Switch OFF
1	TITO* barcode coupon disabled	TITO* barcode coupon enabled
2	\$1 bill disabled	\$1 bill enabled
3	\$5 bill disabled	\$5 bill enabled
4	\$10 bill disabled	\$10 bill enabled
5	\$20 bill disabled	\$20 bill enabled

Table 2-6 DIP Switch Settings (Continued)

WBA Right Side Panel Switches		
		
Default Setting = ALL Switches are OFF		
Switch No.	Switch ON	Switch OFF
6	\$50 bill disabled	\$50 bill enabled
7	\$100 bill disabled	\$100 bill enabled
8	TEST Mode	NORMAL Mode

*. TITO = Ticket In Ticket Out

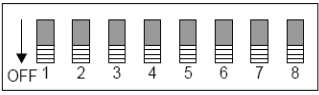
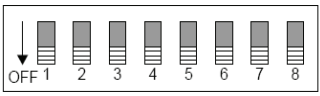

NOTE: DIP Switch settings may vary based on software changes related to the specific country using the WBA. Please contact your local JCM Customer Representative for the latest setting information, or visit the JCM Website at www.jcm-american.com.

WBA-1X and WBA-2X Head Sensor Lens Differences

Figure 2-9 illustrates the WBA 1x-SS and 2X-SS Acceptor Head Lens Differences.

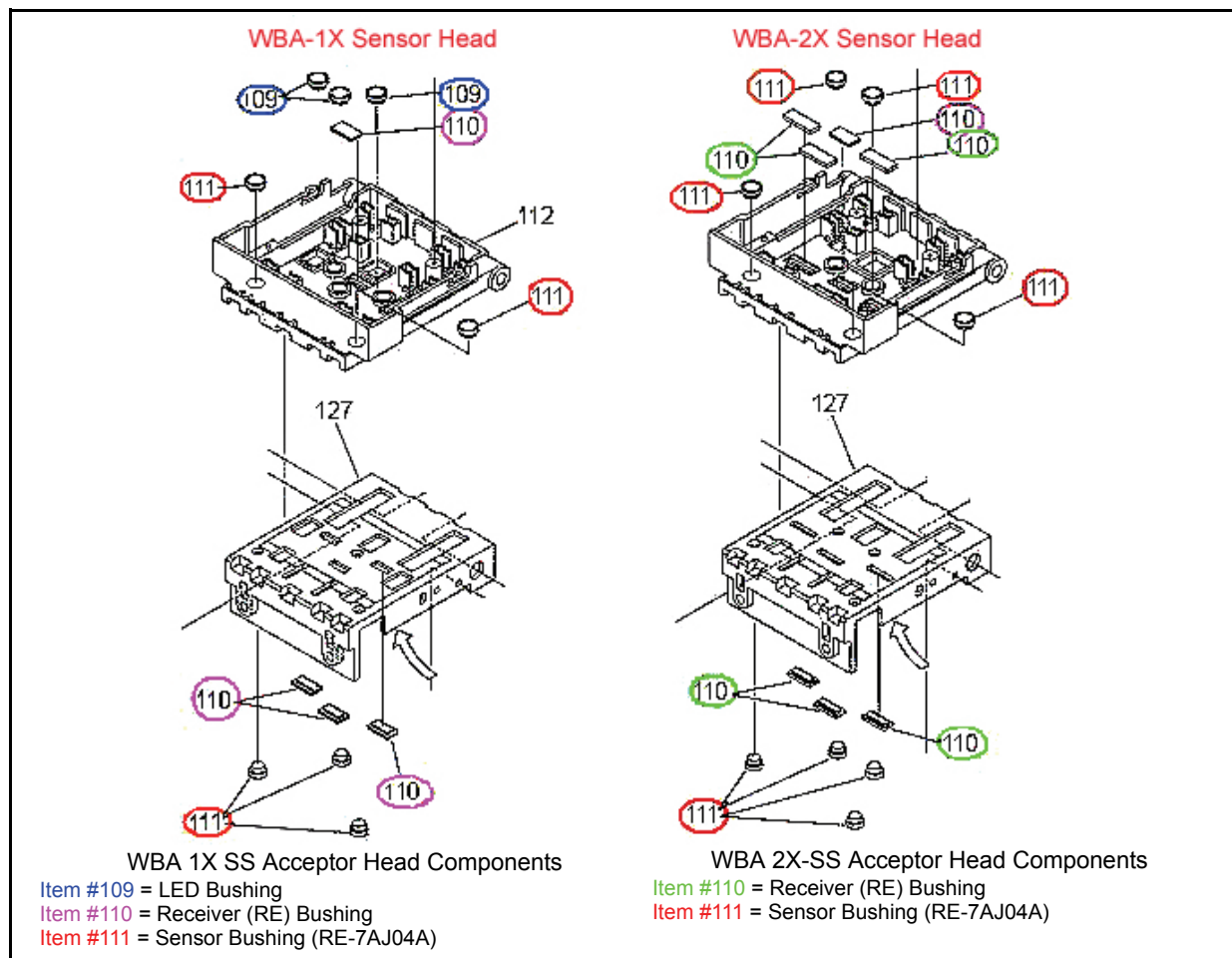

Figure 2-9 WBA 1X-SS & 2X-SS Acceptor Head Lens Differences

Retrieving Bills

To retrieve WBA Cash Box deposited bills, perform the following steps:

1. Push the Release Lever down (See Figure 2-10 a) to release the Cash Box from the frame, and pull the Cash Box forward as illustrated in Figure 2-10 b.

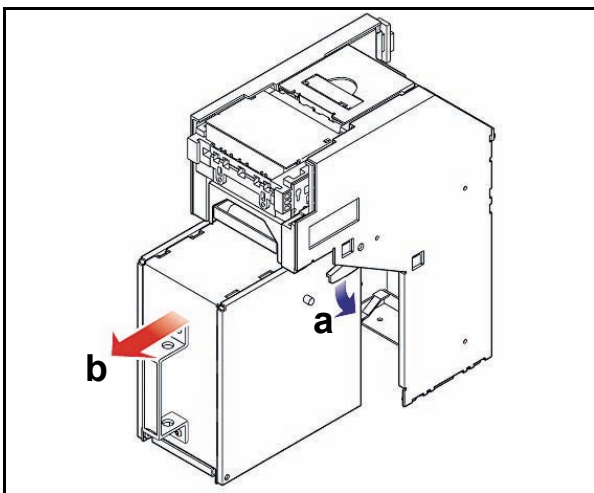

Figure 2-10 Removing the WBA Cash Box

2. Open the Cash Box door and retrieve the bills as illustrated in Figure 2-11.

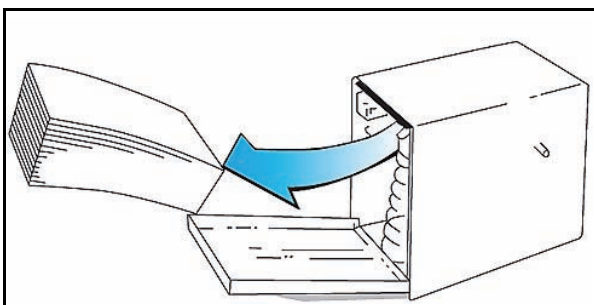

Figure 2-11 Retrieving Bills

Clearing a Bill Jam

When a bill is jammed near the Bill Acceptor's entrance:

1. Pull out on the tabs located on each side of the Acceptor as indicated by the small arrows in Figure 2-12 and
2. Open the units Acceptor's Cover (See Figure 2-12 a).
3. Remove the jammed bill (See Figure 2-12 b).
4. If the jammed bill cannot be removed by opening the Acceptor, pull up on the Transport Unit Open/Close Lever (See Figure 2-13 a)

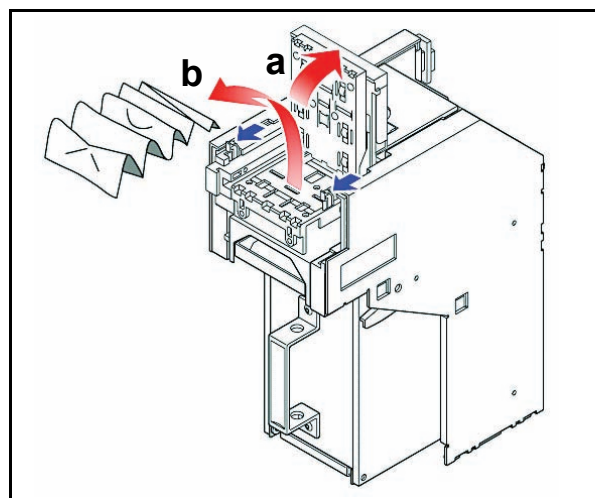

Figure 2-12 Clearing an Entrance Bill Jam

5. Open the Transport Unit Cover (See Figure 2-13 b inset) and
6. Remove the jammed bill (See Figure 2-13 c).

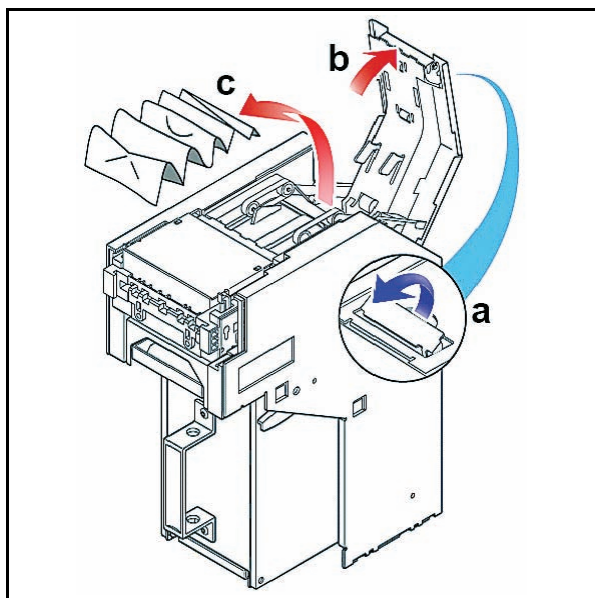

Figure 2-13 Clearing a Transport Unit Bill Jam

1. When a bill is jammed near the Cash Box inlet area, push down on the Cash Box Release Lever (See Figure 2-14 a) and
2. Pull the Cash Box out of the frame (See Figure 2-14 b) and
3. Remove the jammed bill (See Figure 2-14 c).

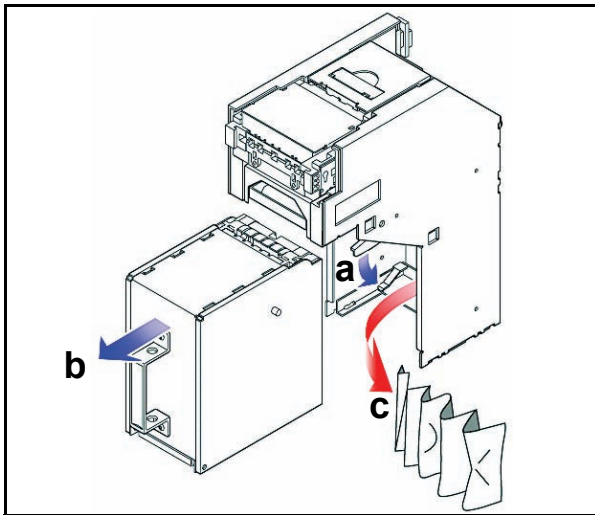

Figure 2-14 Clearing a Cash Box Inlet Bill Jam
Cleaning/Preventive Maintenance

It is important to keep the bill path, rollers, and belts clean. To clean the lenses, use a lint-free cloth and a mild non-abrasive detergent such as liquid dish soap mixed with water. Use a soft lint-free cloth or a cotton swab to wipe dirt and stains from the surfaces of the magnetic and optical sensors, rollers and belts (See Figure 2-15).

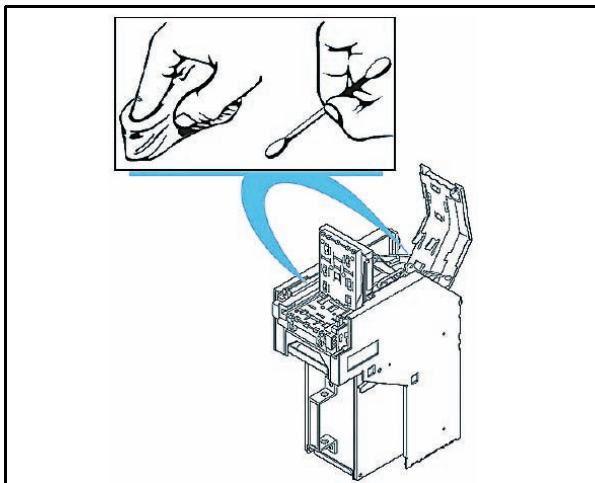

Figure 2-15 Cleaning the WBA Bill Path

The sensor lenses are transparent, and made of a polymer material. Handle them with care. Repeat the cleaning process as needed until the Transport path is free of contaminants.

WARNING: Do not use alcohol, thinner or citrus based products for cleaning any surfaces.

Important: After wiping lenses, inspect them to ensure they are still flush with the bill path.

Available Cleaning Card

A second generation JCM Waffletechnology Bill Validator Cleaning Card is now available (JCM Part No. 501-000141R)(Manufacturer's Part No. KWJCM-B2B15M). The cleaning card is designed to be used as a supplemental part of a Preventive Maintenance program to help in reducing dirt and paper dust build-up within a unit. This will optimize performance between regular Preventive Maintenance intervals.

This is the only cleaning card authorized for use on the WBA Gaming Validator (See Figure 2-16).

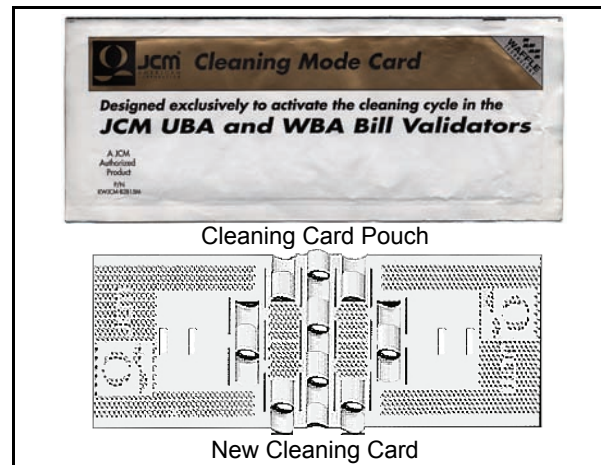

Figure 2-16 JCM Waffletechnology Cleaning Card

CARD FEATURES

- A unique Waffletechnology design that hugs all surfaces to insure complete surface cleaning
- Specially designed scrubber patterns insure that belts and O-ring rollers are cleaned and lubricated to prevent them from drying out.

DIRECTIONS FOR USE

1. Remove cleaning card from pouch and insert it into the Bill Validator.
2. The cleaning card will be accepted and then automatically rejected.
3. Repeat this process several times to ensure debris build-up removal.
4. Insert and HOLD cleaning card while the Validator pulls on it to ensure proper belt cleaning.
5. Dispose of used card in an environmentally safe manner.

For more information and a list of Authorized Waffletechnology Distributors visit:
<http://www.jcmwaffletechnology.com>.

ID-003 Standard Interface Operational Flowchart

Figure 2-17 depicts a typical ID-003 Interface WBA bill acceptance flow process.

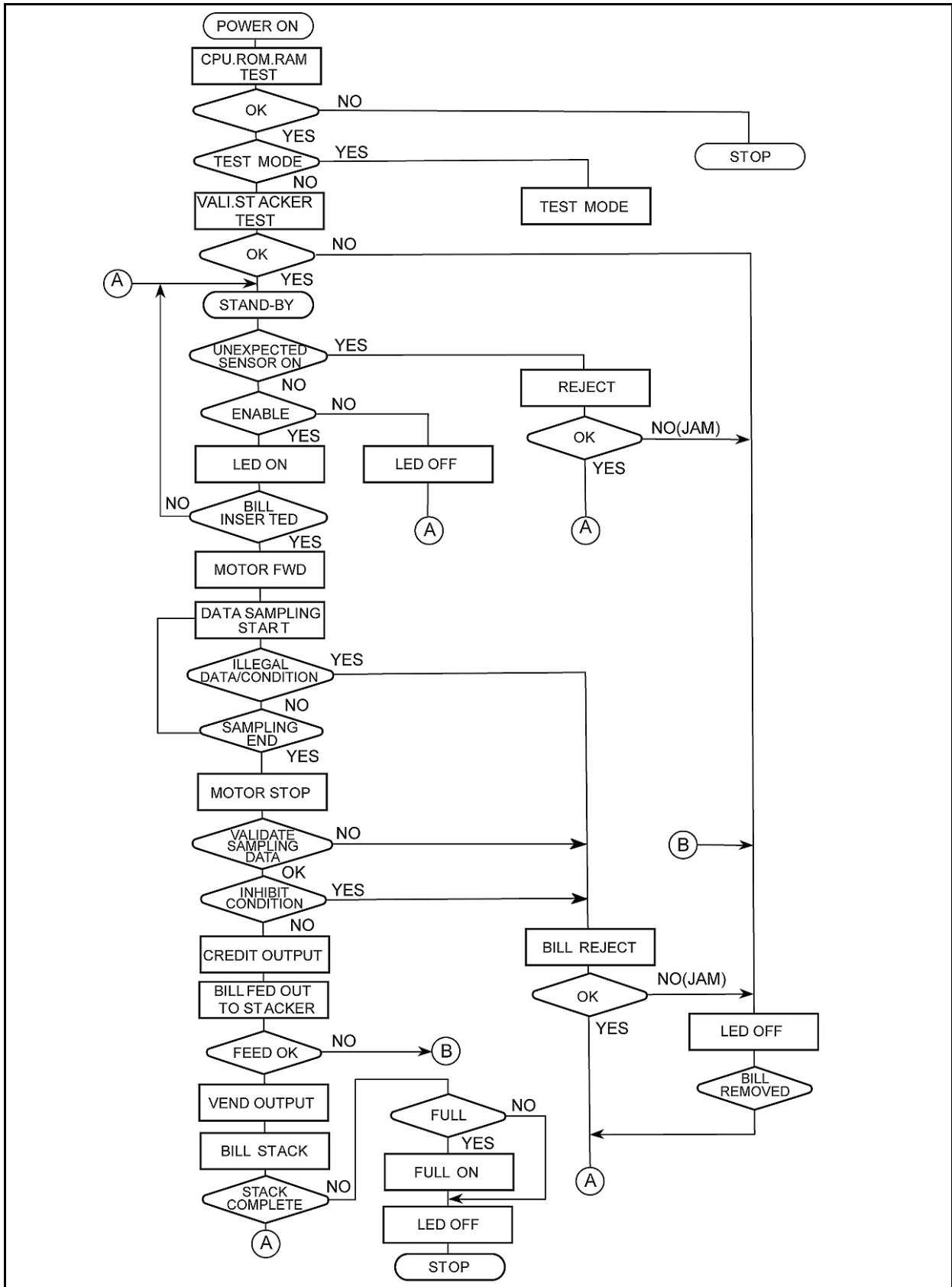

Figure 2-17 WBA Bill Acceptor Operational Flowchart

THIS PAGE INTENTIONALLY LEFT BLANK

WBA[®] Series

World Bill Acceptor (WBA[®]-1x/2x -SS & SS2)

Section 3

3 COMMUNICATIONS

This section was intentionally left out due to a Non Disclosure Agreement requirement.

If this information is required, please contact:

JCM Technical Support
925 Pilot Road
Las Vegas, Nevada 89119
(702) 651-0000

THIS PAGE INTENTIONALLY LEFT BLANK

WBA[®] Series

World Bill Acceptor (WBA[®]-1x/2x -SS & SS2)

Section 4

4 DISASSEMBLY/REASSEMBLY

This section provides disassembly and reassembly instructions for the World Bill Acceptor Series (WBA). This section contains the following information:

- Tool Requirements
- Primary Unit Disassembly
- Acceptor Unit Disassembly
- Transport Unit Disassembly
- Cash Box Disassembly

Tool Requirements

The following tools will be required to perform disassembly and reassembly:

- #1 & #2 Phillips Screwdriver
- Set of Jewelers Phillips Screw Drivers
- E-Clip (E-Ring) Pliers
- Needle Nose Pliers
- Tweezers

Primary Unit Disassembly

The following instructions are provided to perform an initial disassembly of the World Bill Acceptor's primary parts.

1. Pull down on the front round bar Release Latch (See Figure 4-1 a) and pull the WBA Acceptor assembly forward and out of the unit (See Figure 4-1 b).

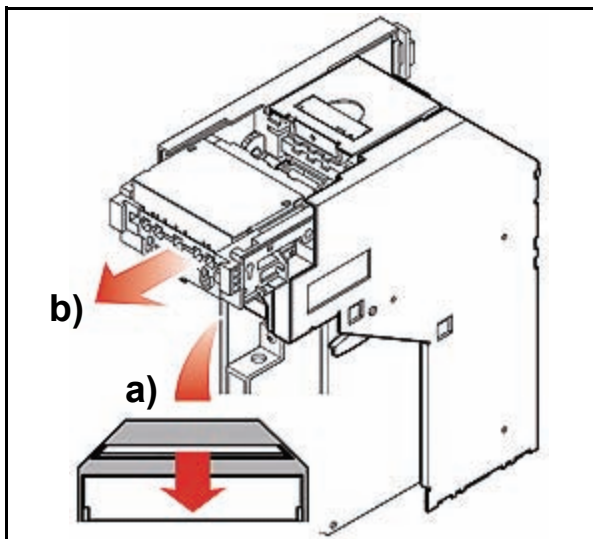

Figure 4-1 WBA Acceptor Head Removal

2. Pull down the Transport Unit Release Lever (See Figure 4-2 a) and pull the transport unit out of the assembly (See Figure 4-2 b).

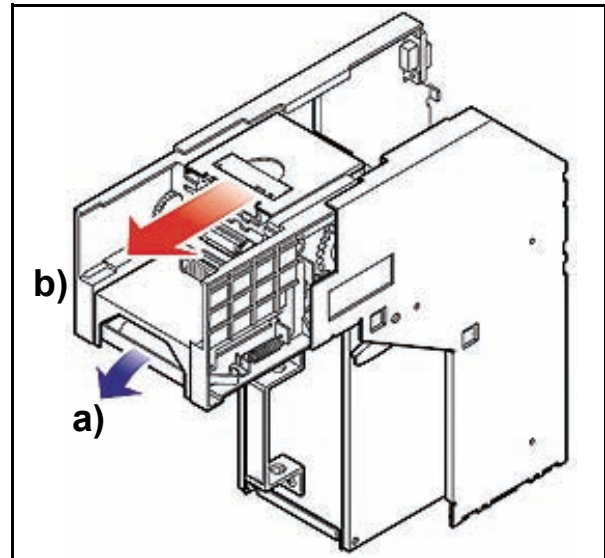

Figure 4-2 WBA Transport Unit Removal

3. Press down on the Cash Box Release Lever (See Figure 4-3 a) and remove the Cash Box from the frame (See Figure 4-3 b).

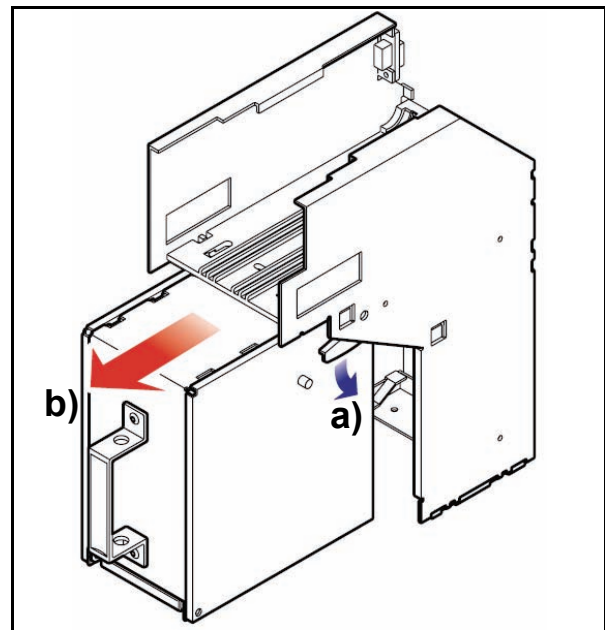

Figure 4-3 WBA Unit Cash Box Removal

Acceptor Unit Disassembly

Upper Sensor Circuit Board Removal

Perform the following steps to remove the WBA Upper Sensor Printed Circuit Board:

1. While pushing down on the two side latches with a small screwdriver (See Figure 4-4 a), slide the metal cover section of the Acceptor in the direction of the large arrow shown in Figure 4-4 b.

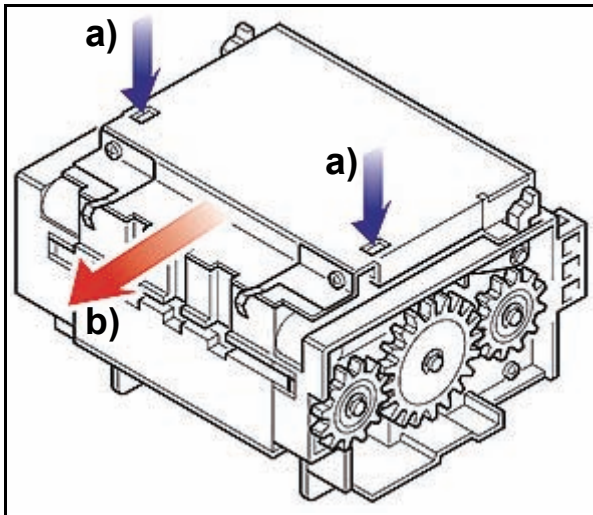

Figure 4-4 WBA Acceptor's Upper Sensor Board Cover Removal

2. Disconnect the harness plug from the Upper Sensor Board (See Figure 4-5 a).
3. Remove the three (3) Upper Sensor Board mounting screws (See Figure 4-5 b) and lift the board up and off the unit.

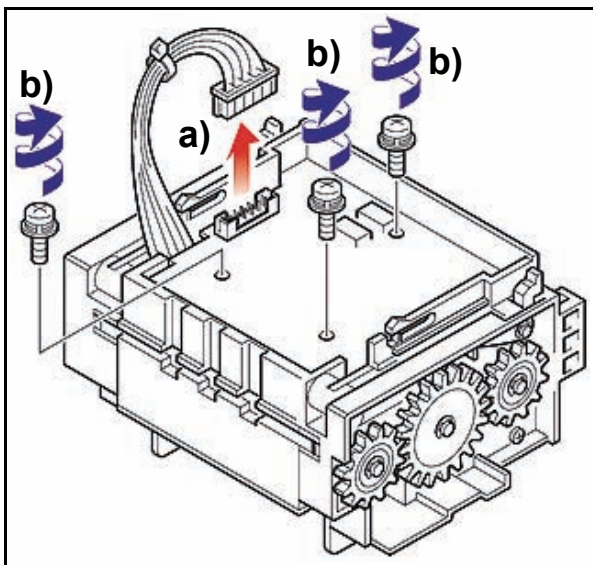

Figure 4-5 WBA Acceptor's Upper Sensor Board Removal

Lower Sensor Circuit Board Removal

Perform the following steps to remove the WBA Lower Sensor Printed Circuit Board:

1. Remove the four (4) Lower Sensor Board Cover mounting screws (See Figure 4-6 a) located on each side of the Acceptor assembly.
2. Carefully lift the Lower Sensor Board Cover up (See Figure 4-6 b) and disconnect the harness plug from the Lower Sensor Board to remove the cover. (See Figure 4-6 c)

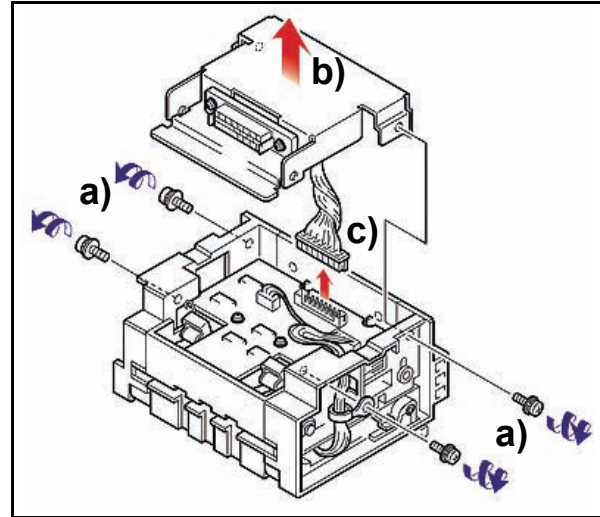

Figure 4-6 WBA Acceptor's Lower Sensor Board Cover Removal

3. Disconnect the two (2) harness plugs from the Lower Sensor Board (See Figure 4-7 a).
4. Remove the three (3) Lower Sensor Board mounting screws (See Figure 4-7 b) and lift the board up and off the unit.

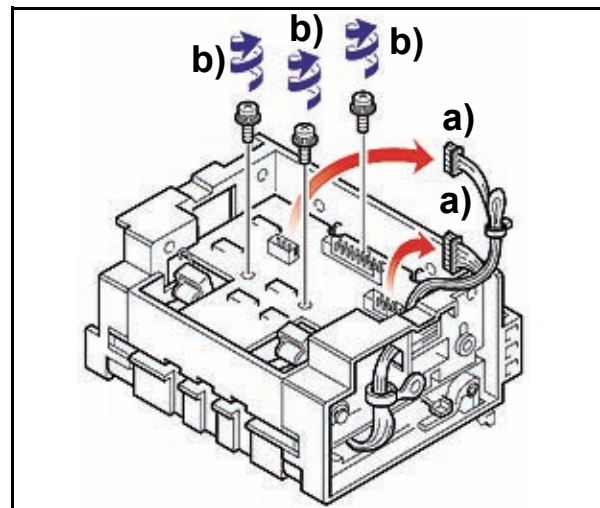

Figure 4-7 WBA Acceptor's Lower Sensor Board Removal

Belt Tension Assembly Removal

Perform the following steps to remove the WBA Acceptor's Belt Tension Assembly:

1. Remove the E-ring from the right rear shaft and remove the small Drive Gear (See Figure 4-8 a).
2. Remove the two (2) screws and two (2) washers securing the Belt Tension Assembly to the housing on each end of the unit (See Figure 4-8 b).

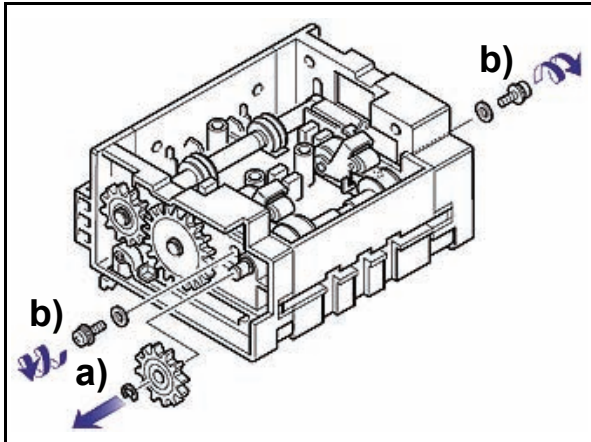

Figure 4-8 Acceptor Head Drive Gear Removal

3. Remove the E-ring from the opposite end of the shaft and push the shaft toward the opposite side where the gear was mounted (See Figure 4-9 a).
4. When shaft movement occurs, two pins that lock the inner gears in place will pop out of their slots. Remove the two pins from the shaft (See Figure 4-9 b).

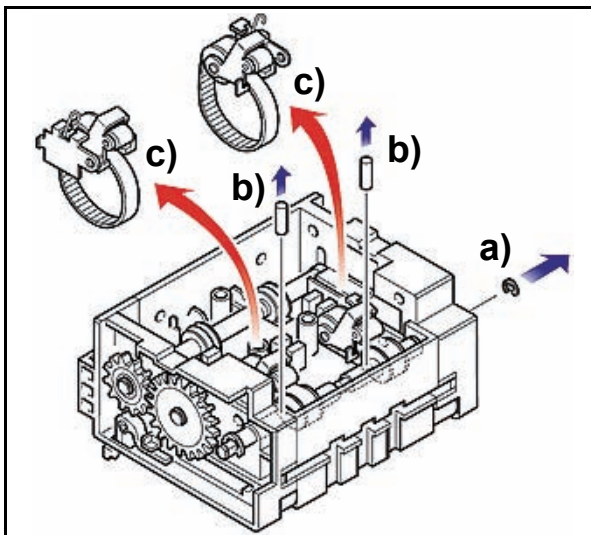

Figure 4-9 Acceptor Head Drive Belt Assembly Removal

5. Pull the shaft completely out of the housing and remove the two (2) Belt Tension Assemblies (See Figure 4-9 c).
6. Remove the E-ring securing the end of each Tension Assembly and disassemble the unit into its respective Belt, Tension Roller, Pulley, Tension Spring, and Shaft Mount (See Figure 4-10 a - f).

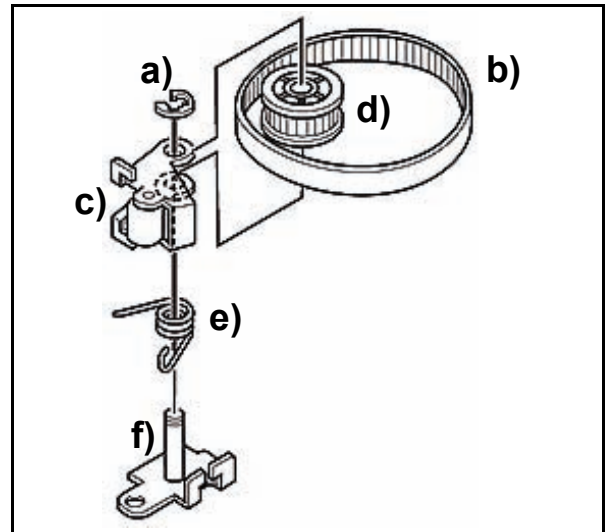

Figure 4-10 Acceptor Head Drive Gear Tension Unit Disassembly

Transport Unit Disassembly

Transport CPU Circuit Board Removal

Perform the following steps to remove the early model WBA-10/11 Transport Unit CPU Board Assembly, or skip to Step 4 if later model unit.

1. Disconnect the nine (9) Harness Connectors from the Transport's CPU Circuit Board (See Figure 4-11).

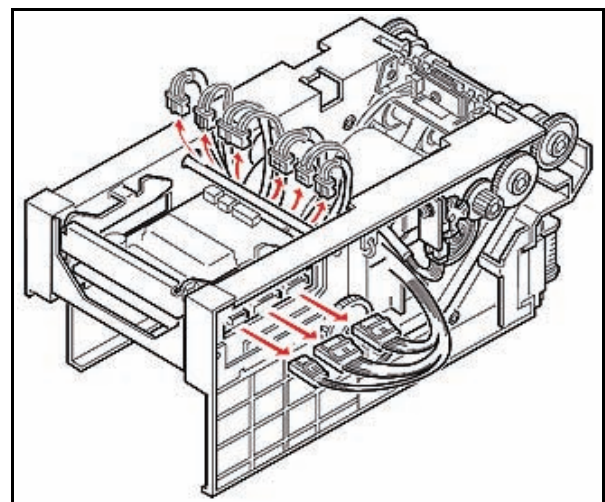

Figure 4-11 WBA 10/11 CPU Board Removal

- Remove the two (2) screws securing the CPU Circuit Board Assembly on each side of the housing (See Figure 4-12 a), and remove the single (1) screw securing the Validator Catch Bar to remove its beam (See Figure 4-12 b).
- Pull the CPU Circuit Board out of the Transport Assembly as indicated by the large arrow in Figure 4-12.

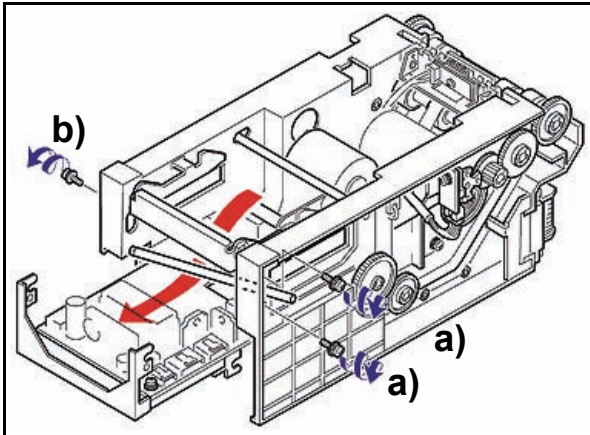

Figure 4-12 WBA Transport CPU Board Assembly Removal

Perform the following steps to remove the WBA12/13 Transport Unit CPU Board Assembly:

- Disconnect the seven (7) Harness Connectors from the Transport's CPU Circuit Board (See Figure 4-13).

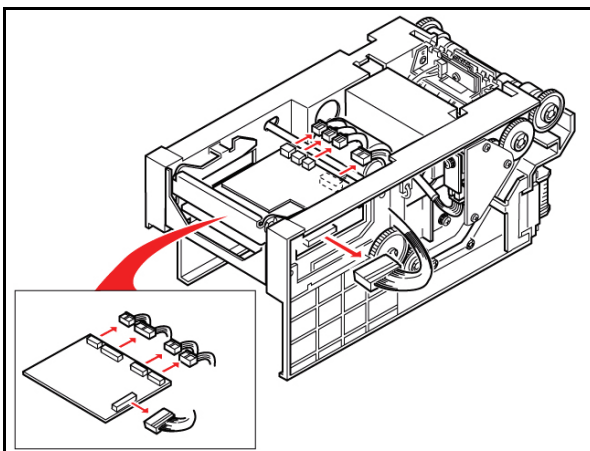

Figure 4-13 WBA 12/13 CPU Board Disconnect

- Remove the two (2) screws securing the CPU Circuit Board Assembly on each side of the housing (See Figure 4-14 a), and remove the single (1) screw securing the Validator Catch Bar to remove its beam (See Figure 4-14 b).

- Pull the CPU Circuit Board out of the Transport Assembly as indicated by the large arrow in Figure 4-14.

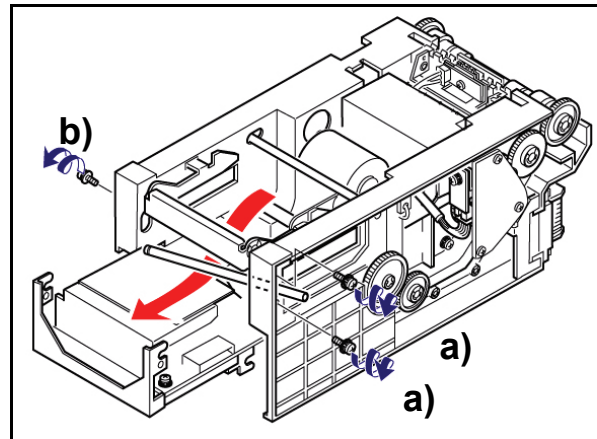

Figure 4-14 WBA Transport CPU Board Assembly Removal

- Remove the single (1) CPU Circuit Board mounting screw (See Figure 4-15 a) and disconnect the harness plug leading to the underside of the board (See Figure 4-15 b).

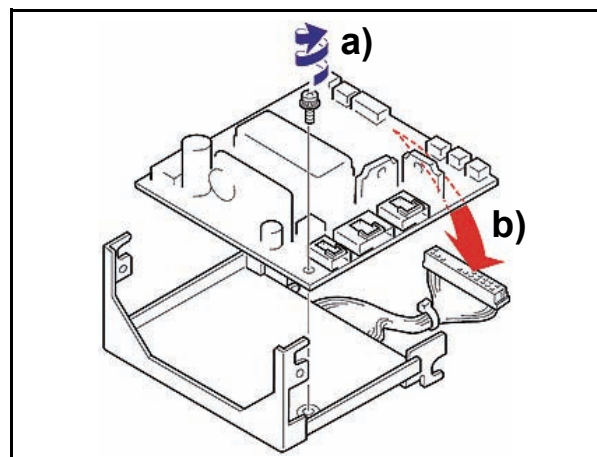

Figure 4-15 Transport CPU Board Removal

Stacker Encoder Sensor Board Removal

Perform the following steps to remove the WBA Transport's Encoder Sensor Board:

- Remove the single (1) Encoder Sensor Board mounting screw and pull the encoder sensor board out of the assembly (See Figure 4-16 a).
- Disconnect the harness plug from the Stack Encoder Sensor Board and remove it from the assembly (See Figure 4-16 b).

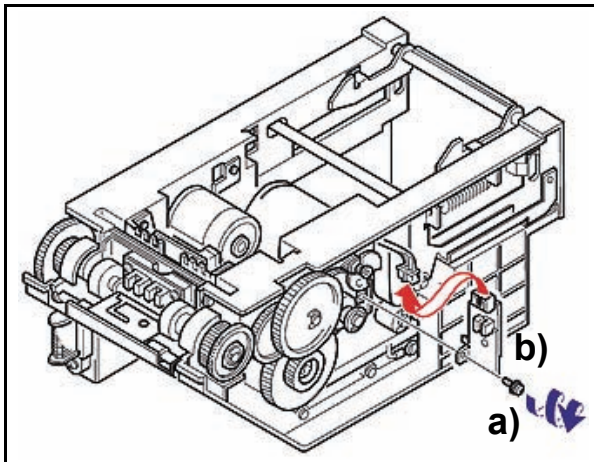

Figure 4-16 Stack Encoder Sensor Board Removal

Stacker Motor Removal

Perform the following steps to remove the WBA Transport's Stack Motor:

1. Insert a screwdriver into the notch of the Stack Motor Encoder blade and remove the motor's two (2) mounting screws (See Figure 4-17 a).
2. Unplug and remove the motor from the assembly (See Figure 4-17 b).

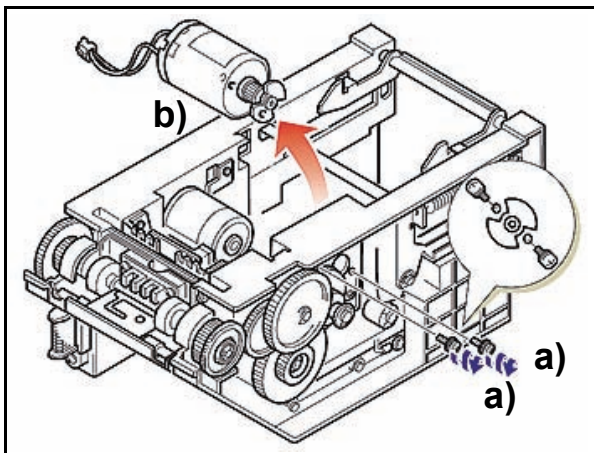

Figure 4-17 Transport Stack Motor Removal

Transport Encoder Sensor Board Removal

Perform the following steps to remove the WBA Transport's Encoder Sensor Board:

3. Remove the single (1) Encoder Sensor Board mounting screw (See Figure 4-18 a), pull the Encoder Sensor Board out away from the Transport Assembly (See Figure 4-18 b) and
4. Disconnect the harness plug from the Encoder Sensor Board to remove it from the assembly (See Figure 4-18 c).

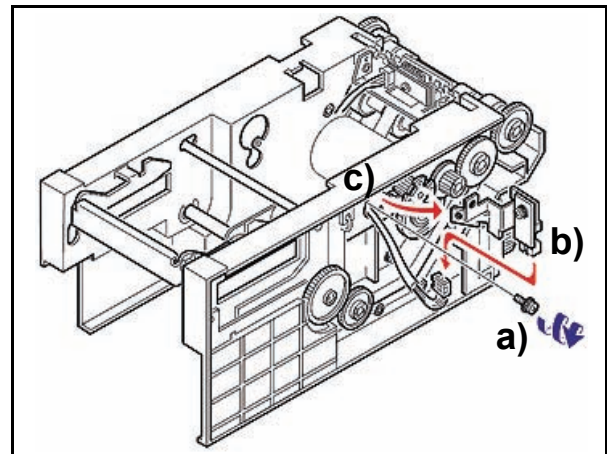

Figure 4-18 Transport Encoder Sensor Board Removal

Transport Drive Motor Removal

Perform the following steps to remove the WBA Transport's Drive Motor:

1. Insert a screwdriver into the notch of the Drive Motor Encoder blade and remove the motor's two (2) mounting screws (See Figure 4-19 a).
2. Unplug and remove the motor from the assembly (See Figure 4-19 b).

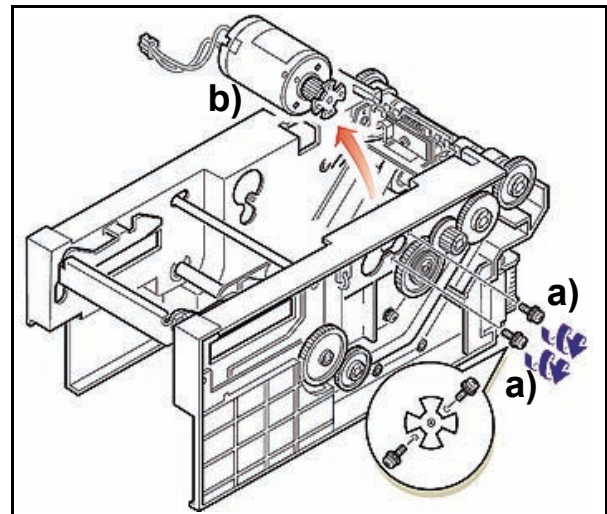

Figure 4-19 Transport Drive Motor Removal

Entrance Lever Sensor Board Removal

Perform the following steps to remove the WBA Entrance Lever Sensor Board:

3. Remove the single (1) Lever Sensor Board mounting screw (See Figure 4-20 a), pull the Lever Sensor Board out away from the Transport Assembly (See Figure 4-20 b) and

4. Disconnect the harness plug from the Lever Sensor Board to remove it from the assembly (See Figure 4-20 c).

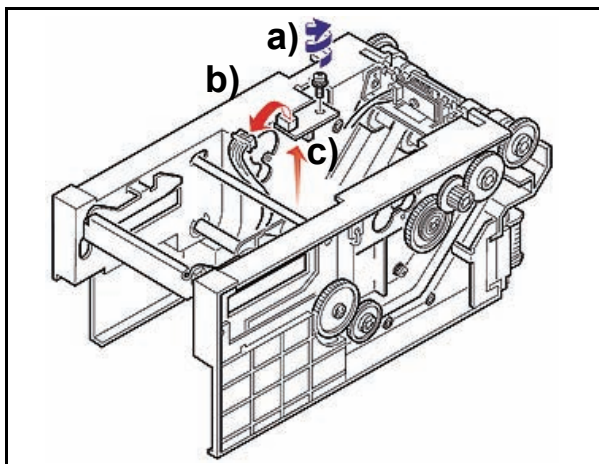

Figure 4-20 Entrance Lever Sensor Board Removal

Solenoid Lever Assembly Removal

Perform the following steps to remove the WBA Solenoid Lever Assembly:

1. Pull up on the Latch Release Lever and lift the entire Solenoid Lever Cover up (See Figure 4-21 a).
2. Remove the single (1) retaining screw located at the Cover's end, and remove the Transport Cover in the arrow direction shown in Figure 4-21 b.

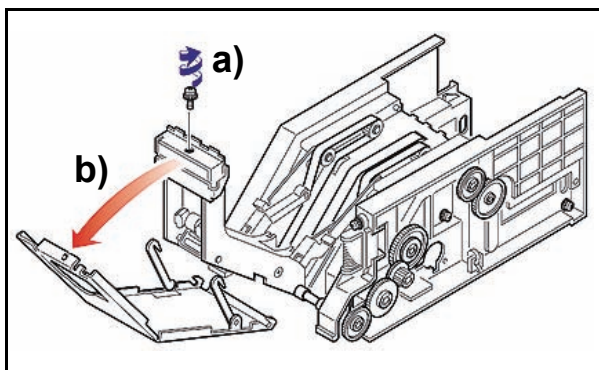

Figure 4-21 Transport Solenoid Cover Removal

Solenoid Lever Sensor Board Removal

Perform the following steps to remove the WBA Solenoid Lever Sensor Board:

1. Remove the two (2) Solenoid Lever Sensor Board mounting screws and disconnect the harness plug from the board to remove it from the assembly (See Figure 4-22 a & b).

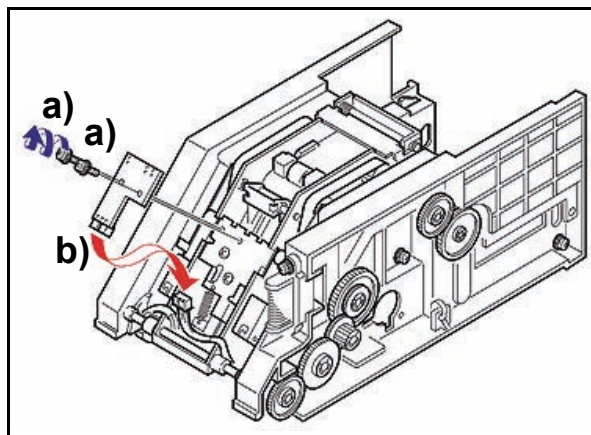

Figure 4-22 Transport Solenoid Lever Sensor Board Removal

Solenoid Lever Assembly Removal

Perform the following steps to remove the WBA Transport's Solenoid Lever Assembly:

1. Remove the spring located at the lower portion of the Solenoid Lever Assembly (See Figure 4-23 a).
2. Remove the two (2) Flat Head mounting screws located on each side of the assembly (See Figure 4-23 b) and the four (4) retaining E-rings on the shaft (See Figure 4-23 c).

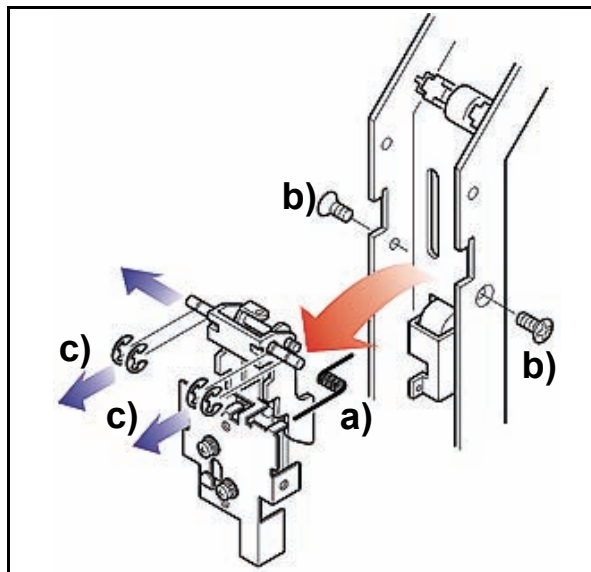

Figure 4-23 Transport Solenoid Lever Assembly Removal

3. Remove the Solenoid Plunger Return spring and the two (2) retaining E-rings on the short plunger shaft located on the previously removed portion of the Solenoid Lever Assembly, and remove the shaft (See Figure 4-24 a, b & c).

4. Disconnect the Lower Roller Return Spring and remove the two (2) Solenoid Mounting Screws to completely disassemble the unit (See Figure 4-24 d & e).

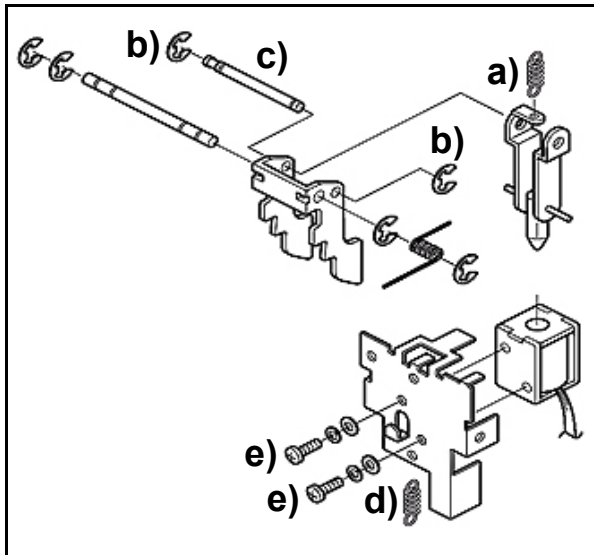

Figure 4-24 Complete Transport Solenoid Lever Assembly's Disassembly

Feed-Out Sensor Assembly Removal

Perform the following steps to remove the WBA Transport's Feed-Out Sensor Assembly:

1. Turn the Transport Assembly upside-down and remove the two (2) Feed-Out Sensor Assembly mounting screws located on each side of the housing (See Figure 4-25 a).
2. Carefully disconnect the harness plug from the Feed-Out Sensor Assembly and remove it from the housing (See Figure 4-25 b & c).

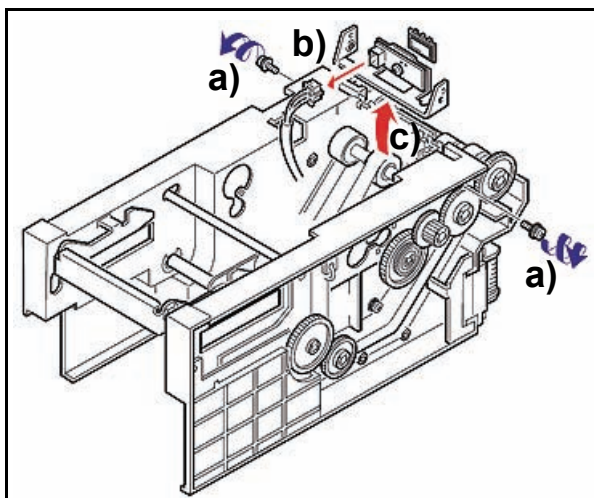

Figure 4-25 Transport Feed-Out Sensor Assembly Removal

Feed-Out Sensor Assembly Disassembly

Perform the following steps to disassemble the WBA Transport's Feed-Out Sensor Assembly:

1. Remove the single (1) screw retaining the Feed-Out Sensor and Lens to the assembly. (See Figure 4-26 a & b).

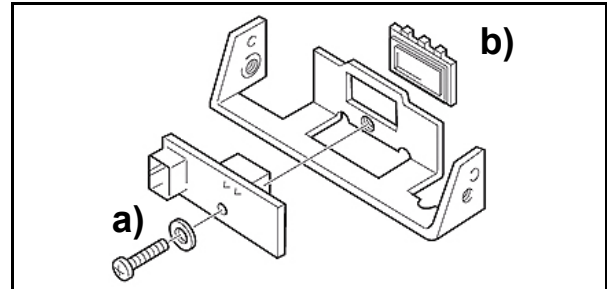

Figure 4-26 Transport Feed-Out Sensor Disassembly

Upper Timing Belt Removal

Perform the following steps to begin removal of the WBA Transport's Upper Timing Belts:

1. Remove the E-ring from the right and left shaft ends (See Figure 4-27 a) and remove the two Drive Gears from the shaft ends. When the left gear is removed, a pin that locks the shaft in place will pop out of its slot.
2. Remove the loose pin from the shaft (See Figure 4-27 b).

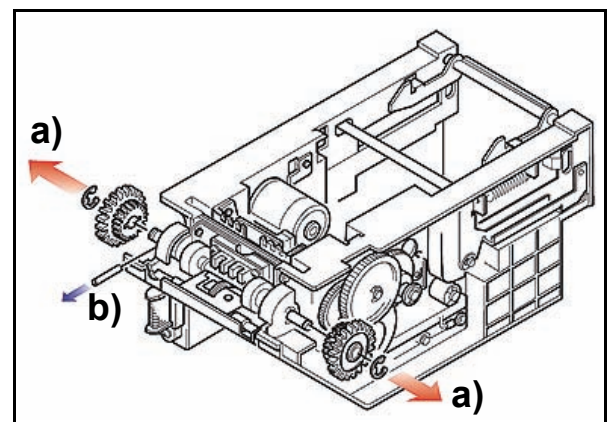

Figure 4-27 Transport Upper Timing Belt Drive Gear Removal

Home Position Sensor Board Removal

Perform the following steps to remove the WBA Transport's Home Position Sensor Board:

1. Remove the four (4) Home Position Sensor Board mounting screws located on each side of the housing (See Figure 4-28 a).

1. Carefully lift the Home Sensor Board Assembly upward (See Figure 4-28 b) and remove the harness plug from the board before removing it from the housing (See Figure 4-28 c).

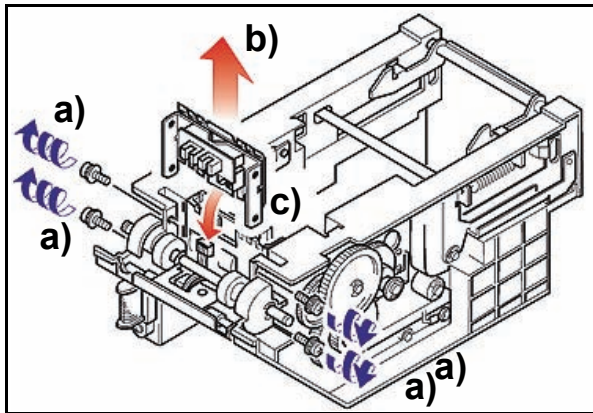

Figure 4-28 Transport Home Sensor Board Removal

Upper Timing Belt Removal Continuation

Perform the following steps to continue removal of the WBA Transport's Upper Timing Belts:

2. Remove the two (2) inner shaft E-rings (See Figure 4-29 a).
3. Remove the single (1) right shaft E-ring and its adjacent washer (See Figure 4-29 b).
4. Next, shift the Timing Belt Wheel towards the right side and remove the two (2) locking pins from the inner shaft (See Figure 4-29 c). The shaft can now be removed from the left side of the assembly (See Figure 4-29 d).
5. Remove the loose Timing Belts.

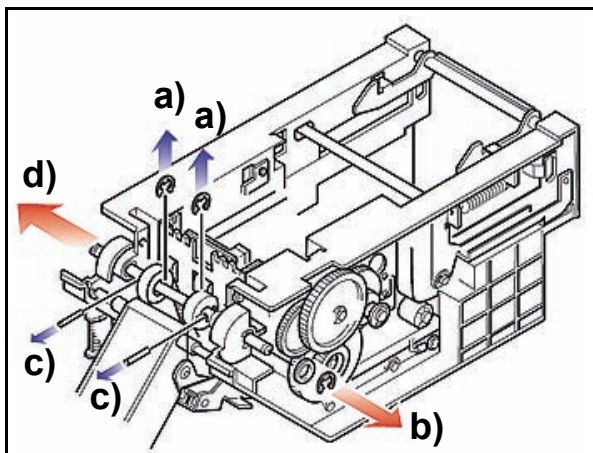

Figure 4-29 Transport Timing Belt Removal

Figure 4-8 better illustrates a complete Transport Timing Belt Shaft component disassembly.

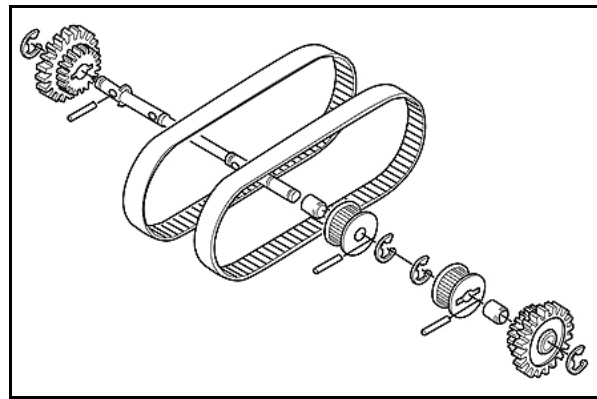

Figure 4-30 Complete Transport Timing Belt Shaft Component Disassembly

Lower Timing Belt Removal

Perform the following steps to remove the WBA Transport's Lower Timing Belts:

1. Remove the three (3) E-rings securing the three (3) right side Drive Gears and remove the gears from the assembly (See Figure 4-31 a).

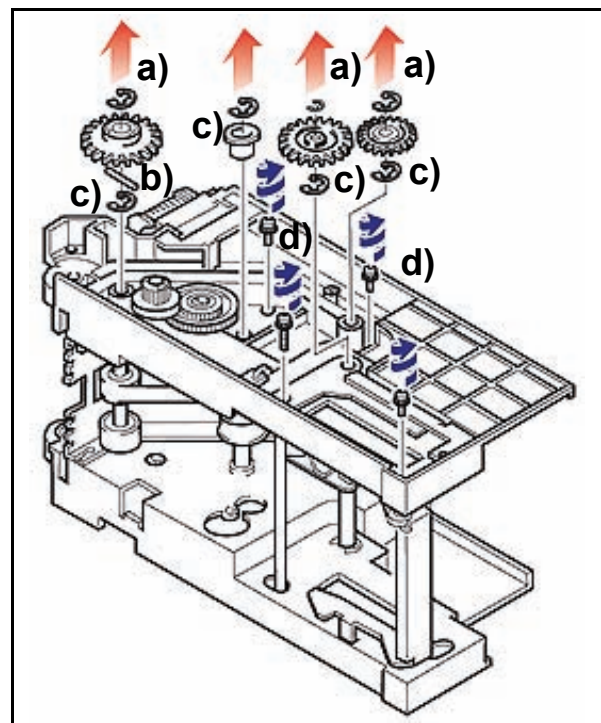

Figure 4-31 Lower Timing Belt Access

2. Remove the single (1) pin located below the large front Drive Gear (See Figure 4-31 b).
3. Remove the remaining four (4) E-rings securing the four shaft ends along with a bushing on the second inside shaft (See Figure 4-31 c).

- Remove the four (4) left side frame mounting screws and separate the side from the four frame supports (See Figure 4-31 d).
- Remove the Lower Timing Belt when the frame side has been separated (See Figure 4-32).

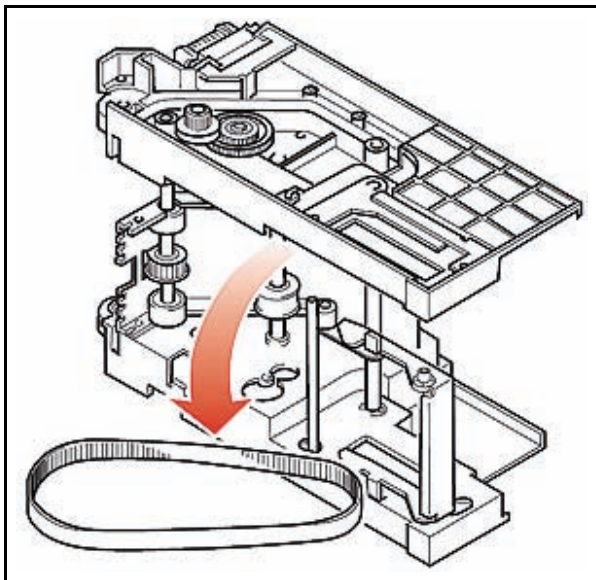

Figure 4-32 Lower Timing Belt Removal

Cash Box Disassembly

Pusher Mechanism Removal

Perform the following steps to remove the WBA Cash Box Pusher Mechanism:

- Remove the two (2) Pusher Mechanism mounting screws (See Figure 4-33 a) and carefully pull the pusher mechanism unit out of the Cash Box frame (See Figure 4-33 b).

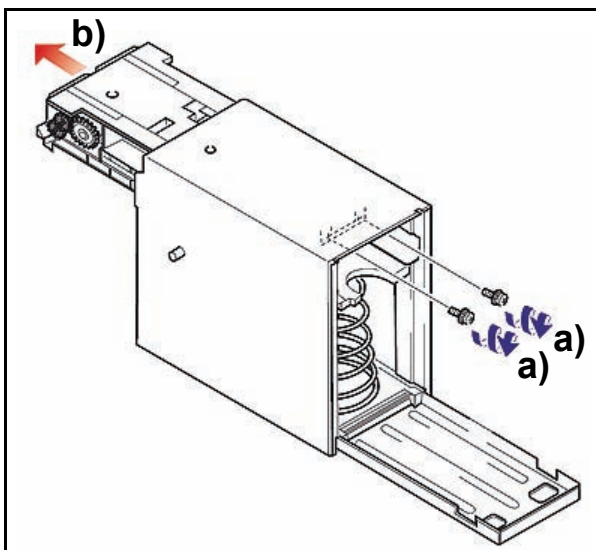

Figure 4-33 Pusher Mechanism Removal

Pusher Mechanism Cover Removal

Perform the following steps to remove the WBA Cash Box Pusher Mechanism Cover:

- Remove the six (6) Pusher Mechanism Cover mounting screws located on each side of the pusher mechanism assembly (See Figure 4-34 a).
- Lift the Pusher Mechanism Cover up and off the assembly (See Figure 4-34 b).

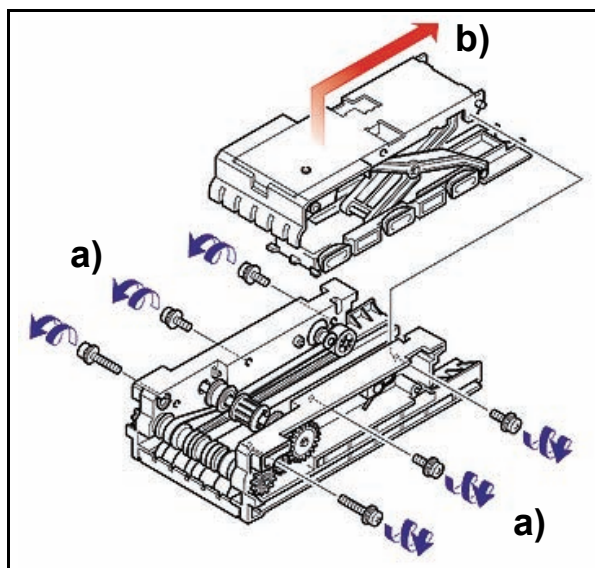

Figure 4-34 Pusher Mechanism Cover Removal

Pusher Mechanism Timing Belt Removal

Perform the following steps to remove the WBA Cash Box Pusher Mechanism Timing Belts:

- Remove the two (2) self tapping screws located on each side of the Pusher Mechanism housing and remove the Coupling Bracket Handle (Figure 4-35 a & b).

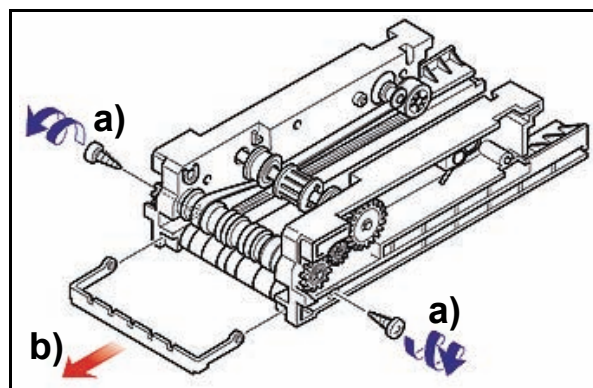

Figure 4-35 Coupling Bracket Handle Removal

- Remove the two (2) Drive Gear securing E-rings and lift the two gears from their respective shafts (See Figure 4-36 a).

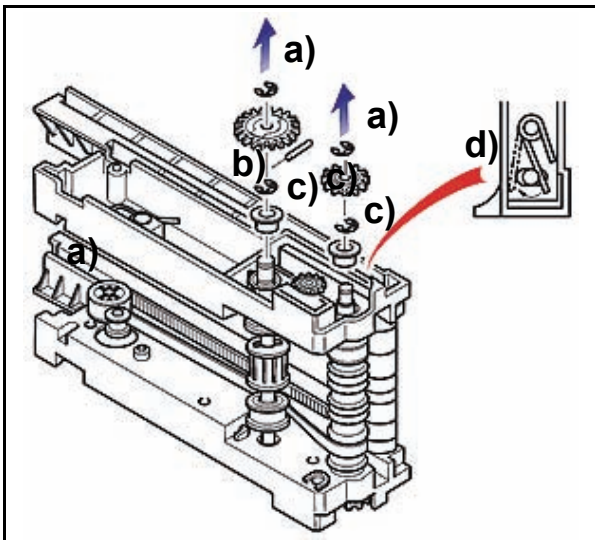

Figure 4-36 Pusher Mechanism Gear Removal

3. Remove the single (1) locking pin below the large gear (See Figure 4-36 b).
4. Remove the two (2) shaft securing E-rings and the two (2) Bushings from the shaft (See Figure 4-36 c).
5. Remove the Shaft Tension Spring set on the small drive gears shaft end (see f inset) on the shaft.(See Figure 4-36 d).
6. Separate the Cash Box side and remove the two (2) Timing Belts (See Figure 4-37 a & b).

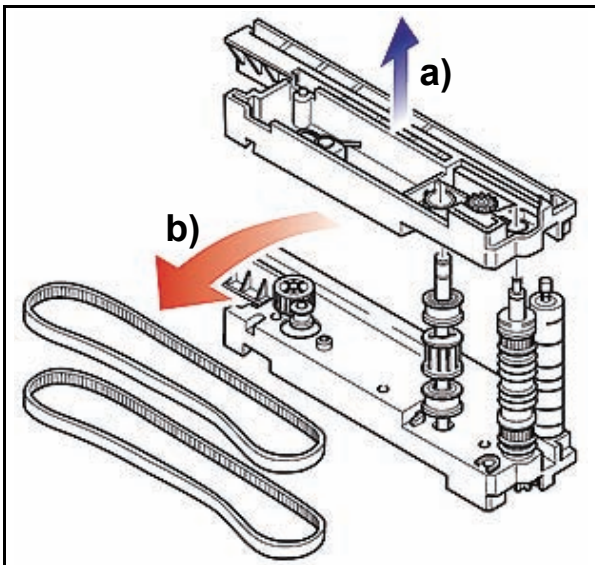

Figure 4-37 Pusher Mechanism Belt Removal

The WBA Disassembly Procedure is now complete. Reverse all of the proceeding instructions to reassemble any of the components described during this disassembly procedure.

WBA[®] Series

World Bill Acceptor (WBA[®]-1x/2x -SS & SS2)

Section 5

5 WIRING DIAGRAMS

This chapter provides the World Bill Acceptor (WBA) Series wiring diagrams and component parts lists for the following items:

- WBA Primary Components

- WBA-14-SS3B System Wiring Diagram
- WBA-15-SS3B System Wiring Diagram
- WBA-24-SS3B System Wiring Diagram
- WBA-25-SS3B System Wiring Diagram

WBA Primary Components Diagram

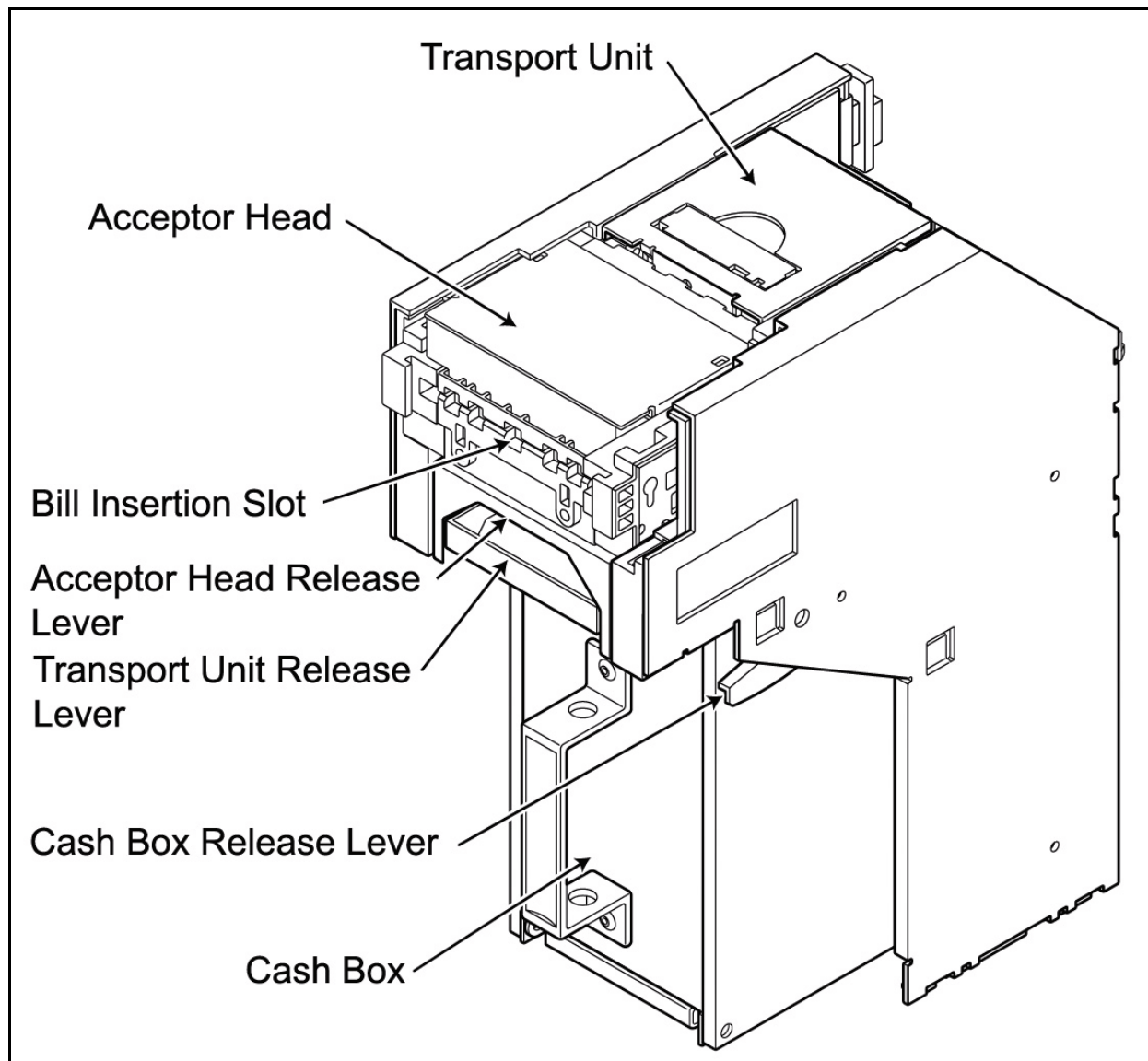

Figure 5-1 World Bill Acceptor (WBA) Primary Components

THIS PAGE INTENTIONALLY LEFT BLANK

WBA-14-SS3B System Wiring Diagram

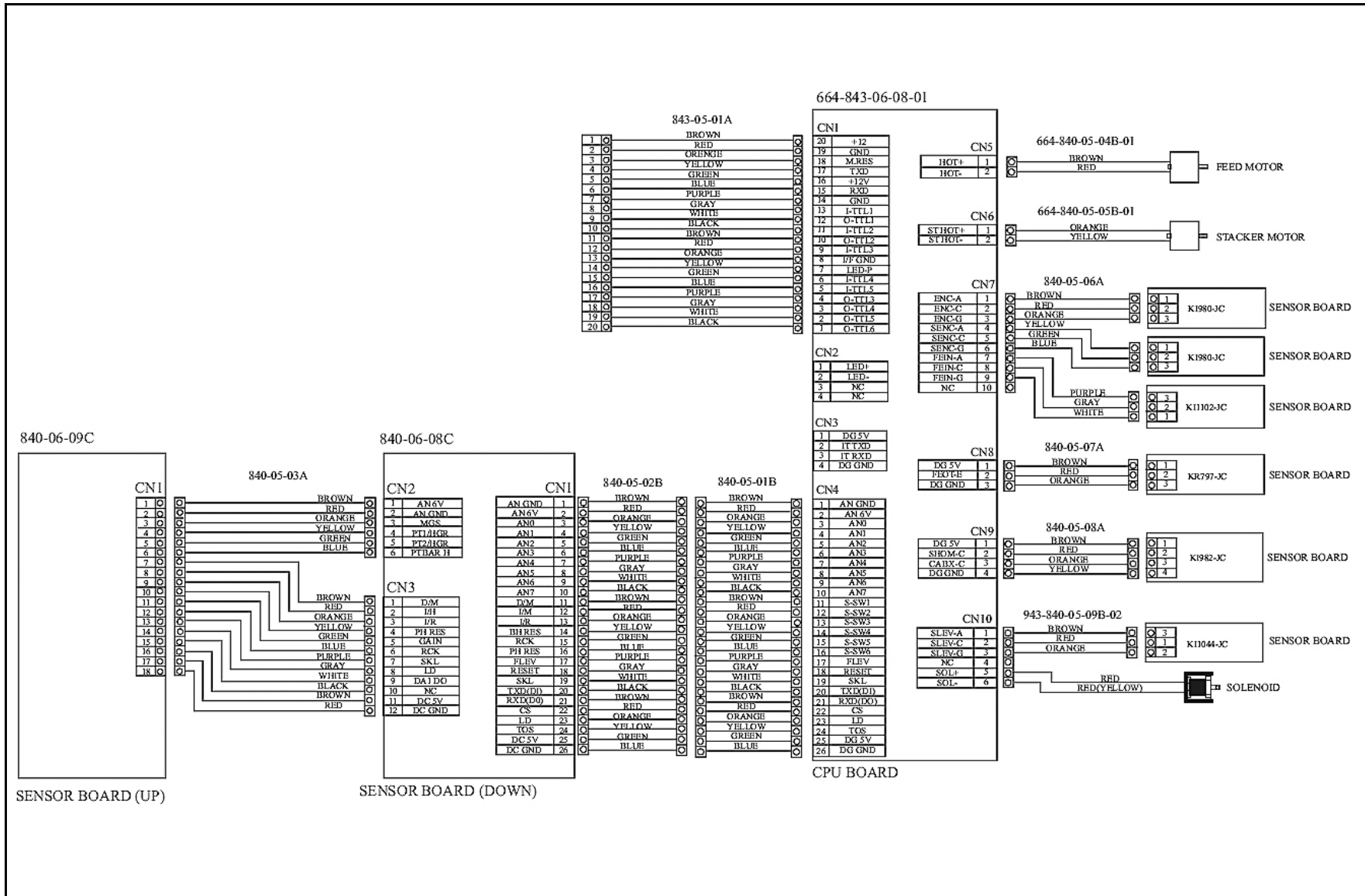

Figure 5-2 WBA-14-SS3B Bill Acceptor System Wiring Diagram

WBA-15-SS3B System Wiring Diagram

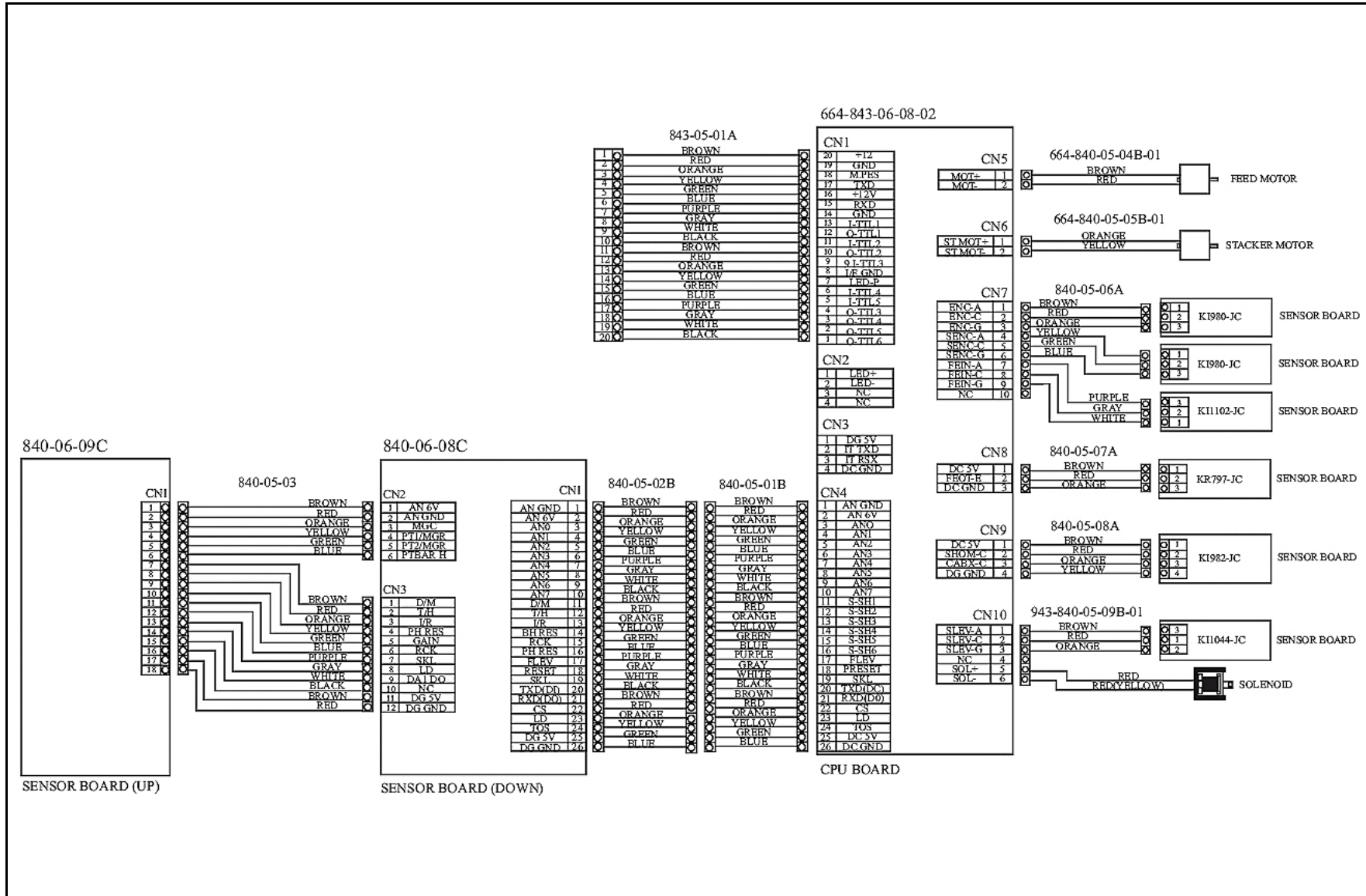

Figure 5-3 WBA-15-SS3B Bill Acceptor System Wiring Diagram

WBA-24-SS3B System Wiring Diagram

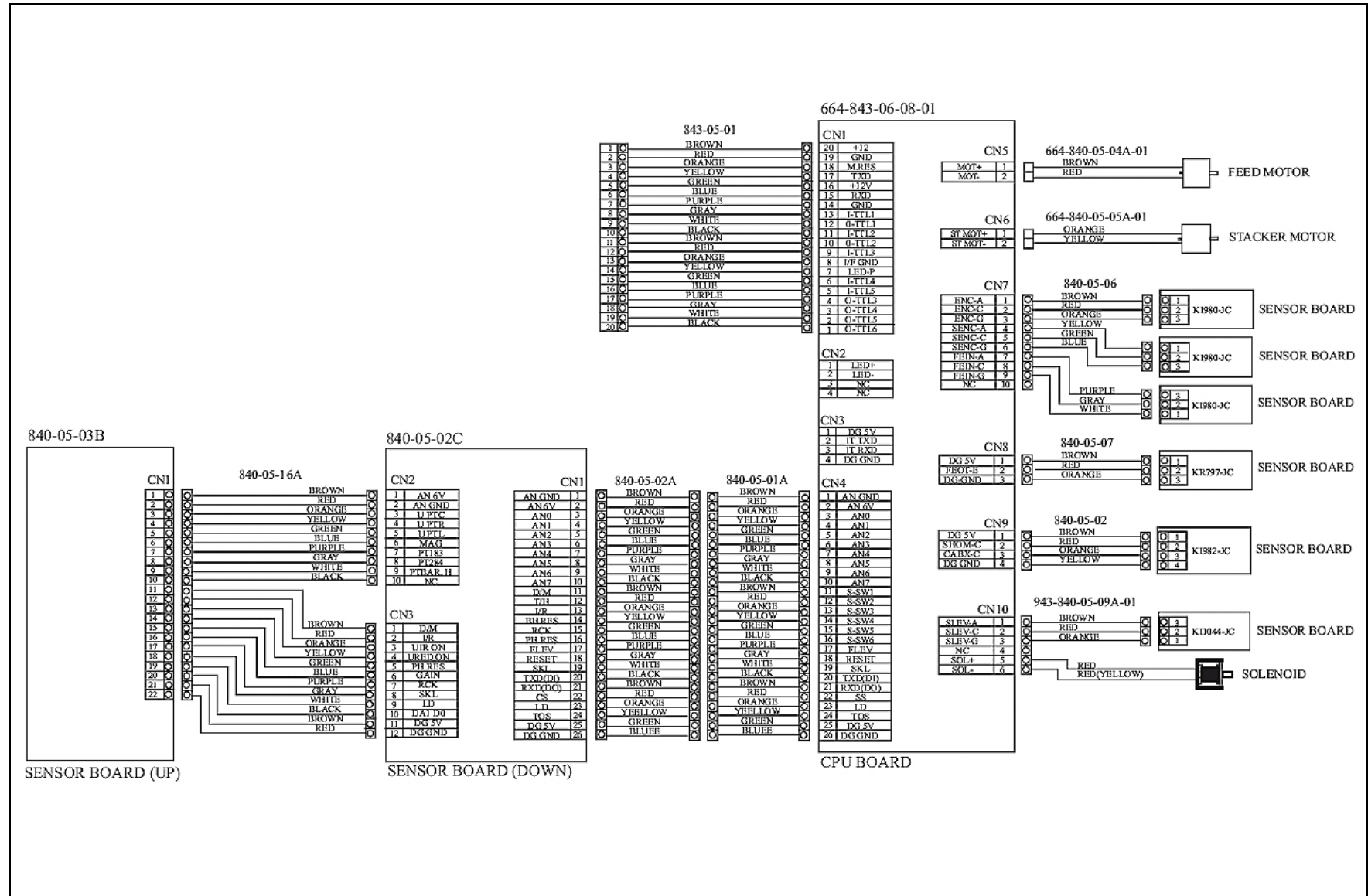

Figure 5-4 WBA-24-SS3B Bill Acceptor System Wiring Diagram

WBA-25-SS3B System Wiring Diagram

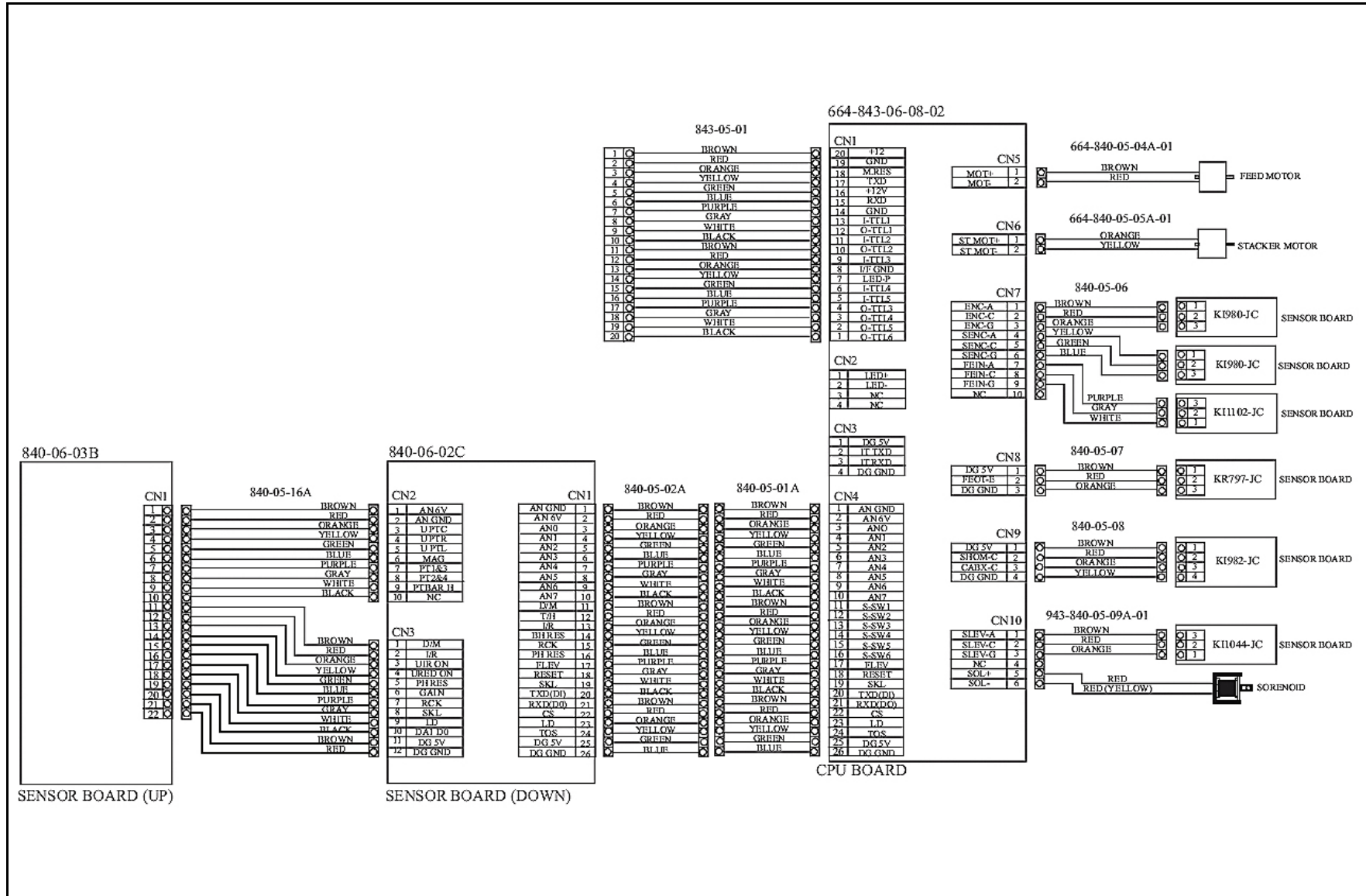

Figure 5-1 WBA-25-SS3B Bill Acceptor System Wiring Diagram

WBA[®] Series

World Bill Acceptor (WBA[®]-1x/2x -SS & SS2)

Section 6

6 CALIBRATION AND TESTING

This section provides Flash EPROM Memory Download Programming, Calibration, and Performance Testing instructions for the World Bill Acceptor Series (WBA). This section contains the following information:

- Workbench Tool Requirements
- Software Download Preparation
- Software Downloading Procedure
- Programming Instructions
- Calibration Procedures
- Performance Tests

Workbench Tool Requirements

The following tools are required to perform a workbench software download (See Figure 6-1):

- JCM World Bill Acceptor (WBA)
- JCM PS15-006 External Power Supply (Part No. 550-100042) or equivalent
- PC containing a free COM Port (OS: Windows 2000/XP)

- The latest WBA Download Program CD (obtain from your JCM Sales Representative)
- Black, White and Mag Tool Calibration Paper (Figure 6-1 lists the specific part number requirements for your particular unit).

Software Download Preparation

The following instructions describe how to decompress and store a downloaded program onto a personal computer (PC) for eventual installation into the World Bill Acceptor:

1. Refer to the Figure 6-1 interconnection diagram to properly connect the power supply, various cables and wiring harnesses to the WBA.

Warning: Make sure the External Power Supply is OFF when connecting the harness to the WBA. Failure to do so may cause electrical shock and/or permanent damage to the equipment.



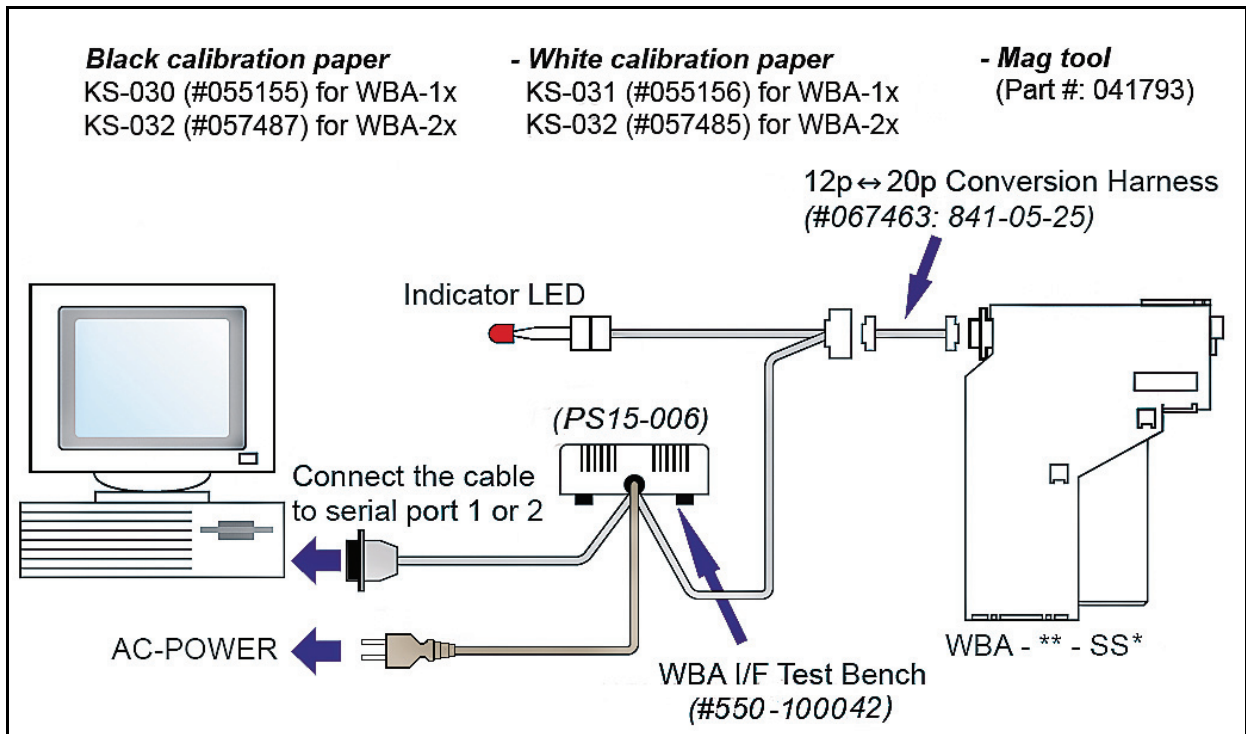

Figure 6-1 Required WBA Download Workbench Tools

2. Figure 6-2 illustrates the WBA's external port, DIP Switch locations and their initial settings. To prepare the WBA for download set the DIP Switches as follows:
 - Set DIP Switch No. 8 to ON and
 - Set DIP Switches No. 1 through 7 OFF.

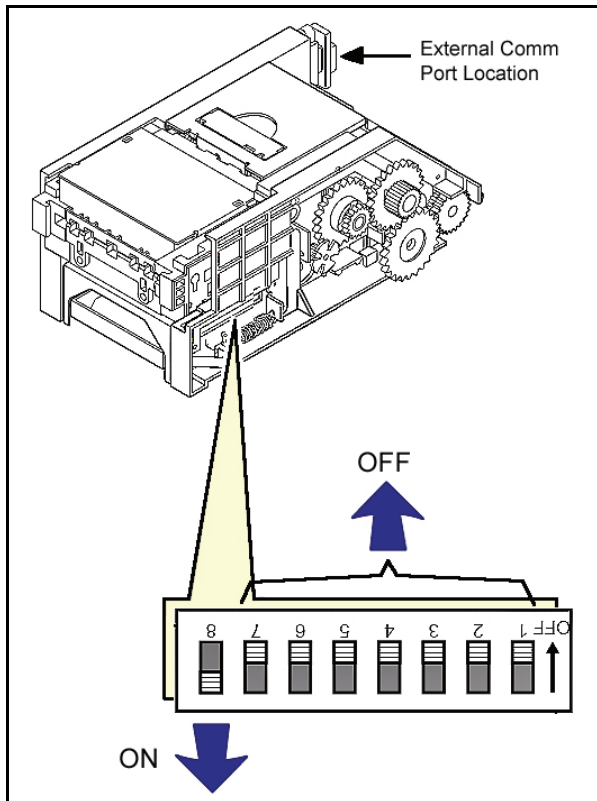

Figure 6-2 WBA DIP Switch & Port Location

3. Supply power to the WBA. The RED Indicator LED will flash approximately once every second.
4. Set Dip Switch No. 8 to OFF.

Software Downloading Procedure

Program Installation

The following PC initialization functions are required prior to running the downloaded software.

1. Create and name a new folder on your PC.
2. Decompress the .ZIP file and save the expanded file program contents in the file folder just created.
3. Double-click on the associated file to start the program (i.e., "ADJ10Win_e.exe" for WBA-12/13, "ADJ20Win_e.exe" for WBA-22/23/24/25).

Calibration Procedure

When the WBA-1x Series Adjustment Program **JCM WBA-1x Series Adjustment Program** begins, the Figure 6-3 Screen will appear. Before proceeding check that the software name, type, and version number are correct related to your particular country's currency type.

To end the software installation process at this point without recalibrating the WBA, press the "Exit" Screen Button.

1. Click on the "Start" Screen Button and the Figure 6-4 Screen will appear.
2. Confirm that the Validation Head is properly installed before proceeding.



Figure 6-3 Initial Setup Screen

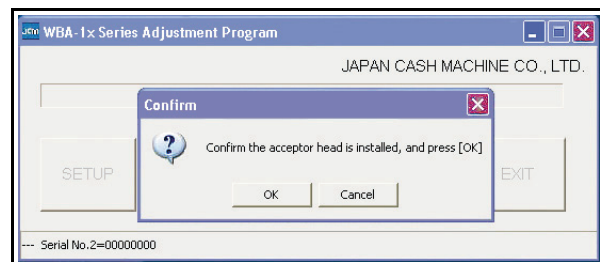

Figure 6-4 Head Installed Confirmation

3. When the Acceptor Head installation is verified, click on the "OK" Screen Button and the Figure 6-5 Screen will appear.

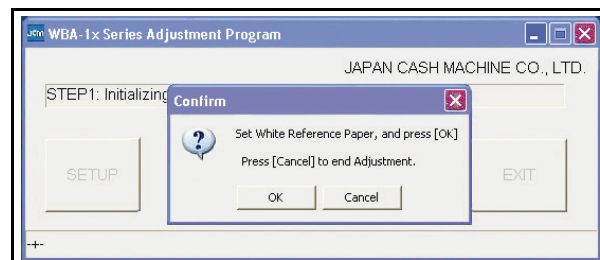

Figure 6-5 White Paper Calibration Screen

4. Open the Acceptor Head and Insert the White Calibration Paper ("KS-030" for WBA-12/13 or "KS-032" for WBA-22/23/24/25) as shown in Figure 6-6 and illustrated in Figure 6-7 a respectively.

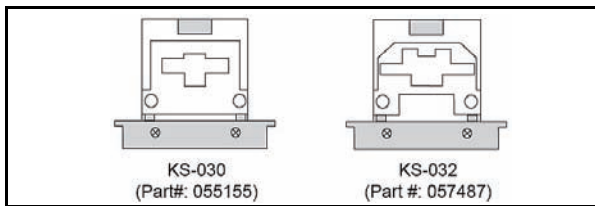

Figure 6-6 White Calibration Paper Types

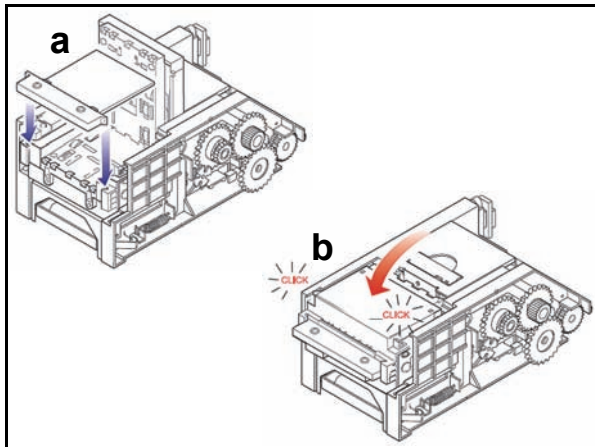

Figure 6-7 Inserting White Calibration Paper

5. Close the Acceptor Head and make sure that the tabs on both side of the Acceptor Head firmly “Click” lock in place (See Figure 6-7 b).
6. Click on the “OK” Screen Button to start the “Adjusting with White Reference Paper” calibration procedure. When calibration begins the Figure 6-8 Screen will appear.



NOTE: Do not move the Acceptor Head or the calibration paper during the calibration procedure.

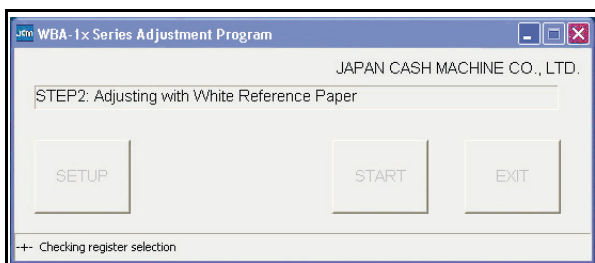

Figure 6-8 White Calibration Occurring Screen

7. When White Paper Calibration is complete, the Figure 6-9 Screen will appear; at this point insert the Black Calibration Paper (“KS-031” for WBA-12/13 or “KS-033” for WBA-22/23/24/25) as shown in Figure 6-10 and illustrated in Figure 6-11 a respectively.
8. Close the Acceptor Head and make sure that the tabs on both side of the Acceptor Head firmly lock in place (See Figure 6-11 b).

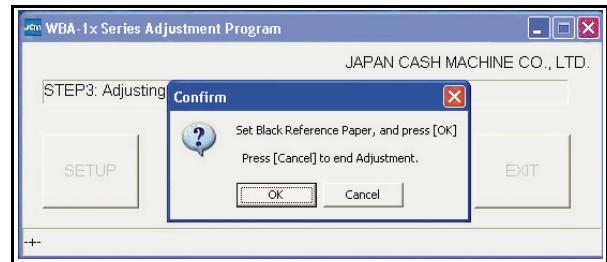

Figure 6-9 Black Paper Calibration Screen

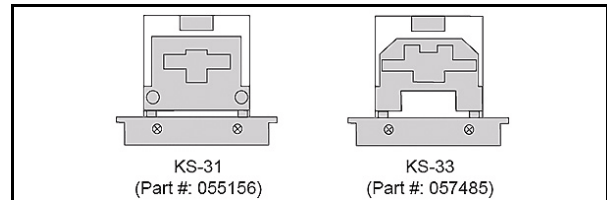

Figure 6-10 Black Calibration Paper Types

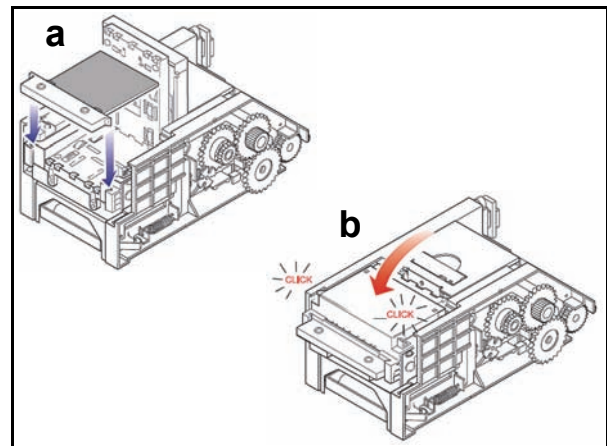

Figure 6-11 Inserting Black Calibration Paper

9. Click on the “OK” Screen Button to start the Black Reference Paper calibration procedure.



NOTE: Do not move the Acceptor Head or the calibration paper during the calibration procedure.

When calibration begins the Figure 6-12 Screen will appear.



Figure 6-12 Black Calibration Occurring Screen

When the Black Reference Paper calibration procedure is complete, the Figure 6-5 Screen will re-appear (See Figure 6-13).

10. At this point re-insert the White Calibration Paper and click on the “OK” Screen Button to re-start the “Adjusting with White Reference Paper” calibration procedure again.



Figure 6-13 White Re-Calibration Request Screen

11. Repeat Steps 5 through 9 three to five times until the Figure 6-14 Screen appears.



Figure 6-14 Remove Calibration Paper Screen
Calibration with White and Black Paper is now complete. Remove the final calibration paper and close the Acceptor Head (See Figure 6-15 a). Make sure that the tabs on both side of the Acceptor Head are once again firmly locked in place (See Figure 6-15 b).

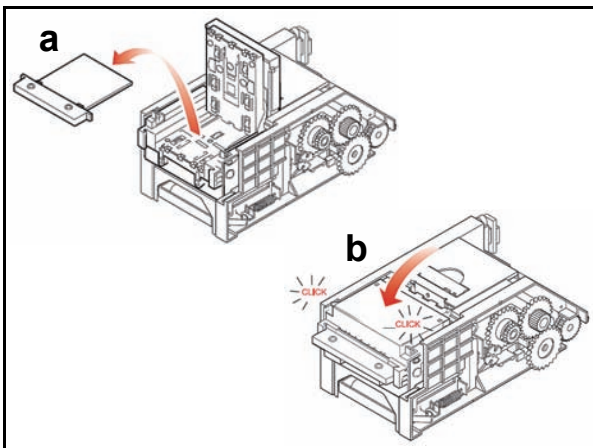

Figure 6-15 Removing Final Calibration Paper

12. Click on the “OK” Screen Button to start the paperless calibration procedure (i.e., no calibration paper inserted).

When calibration begins the Figure 6-16 Screen will appear.



Figure 6-16 Paperless Calibration Screen

13. When the paperless calibration process is complete, the Figure 6-17 Screen will appear.



Figure 6-17 Magnetic Test Calibration Screen

14. Insert the MAG Head Test Board into the Acceptor and find the location where the second line of MAG Head Test Board just aligns above the Acceptor Head Roller located on the lower tray (See Figure 6-18). Make sure that the tabs on both side of the Acceptor Head are once again firmly locked in place.



NOTE: Closing the Acceptor Head once the calibration process starts will result in an erroneous reading!

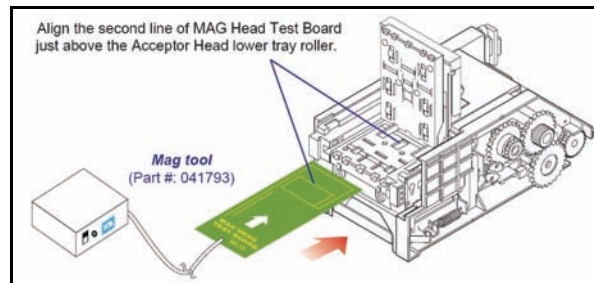

Figure 6-18 Aligning the MAG Head Calibration Test Board

15. Click on the “OK” Screen Button to start the MAG Head Tester Calibration procedure. The Figure 6-19 Screen will appear showing the current value (a) and the peak value (b) detected after the MAG Board has been inserted.

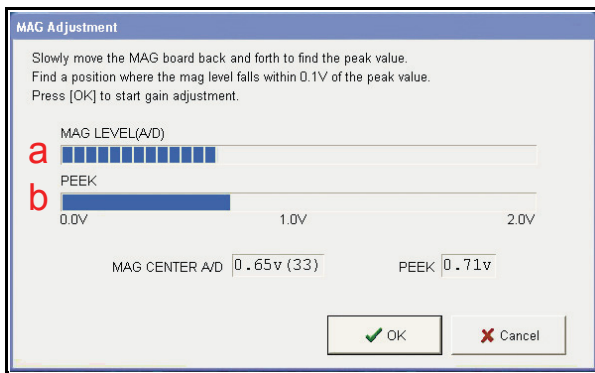

Figure 6-19 Magnetic Adjust Value Screen

16. Slowly move the MAG Head Test Board in and out of the Acceptor Head to locate the maximum peak value (See Figure 6-20). Peak value (b) should read between 0.5V and 1.2V when within the proper range.

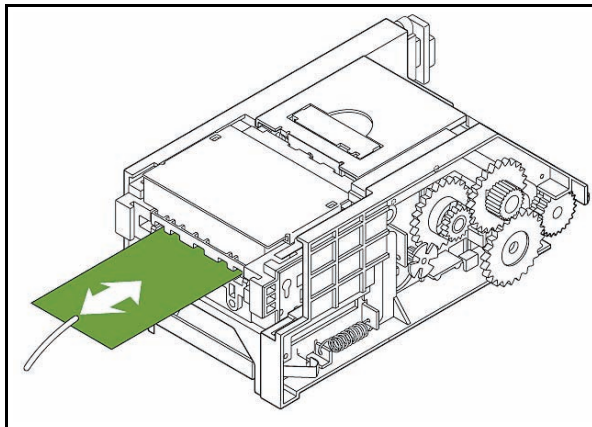

Figure 6-20 Locating the MAG Head Calibration Peak Value Reading

17. Continue to slowly move the MAG Head Test Board in and out several millimeters to locate the position where the "MAG Center A/D" value enters a range within -0.1Volts in relation to the peak value detected.
18. When the "MAG Center A/D" value enters the designated range, press the "OK" Screen Button. The calibration process will begin and the Figure 6-21 Screen will appear.



Figure 6-21 Adjusting Magnetic Gain Screen

19. When calibration is complete, the Figure 6-22 Form 1 Screen will appear providing a prompt asking if the current adjustment data results should be written into the Acceptor Head Memory.

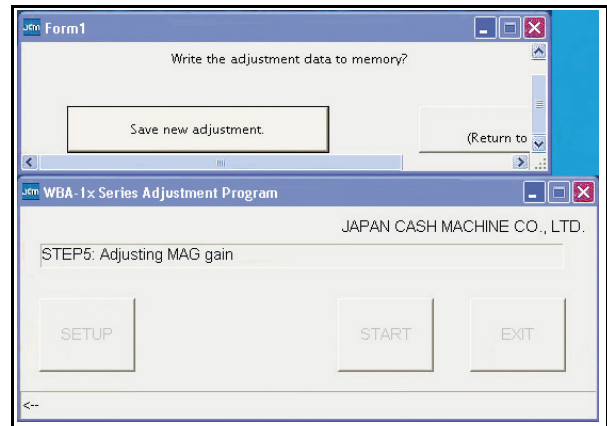

Figure 6-22 Write Value Prompt Screens

20. Press the "Save new adjustment." Screen Button and then the Click on the "OK" Screen Button to write the data into memory if it is acceptable (See Figure 6-23).

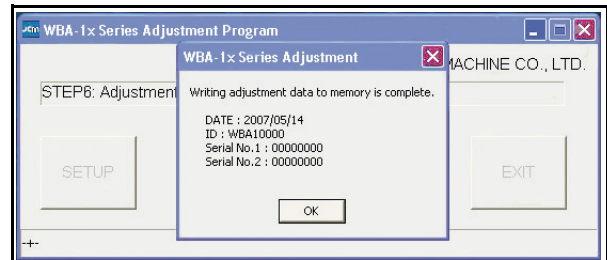

Figure 6-23 Writing Adjustment Data Screen

If it is not, press the "Return to MAG Adjustment" Screen Button or press the key, and the original data will automatically return deleting all of the current adjustment data collected.

21. When the Figure 6-24 Screen appears, all calibration procedures are complete.



Figure 6-24 End Calibration Screen

If another WBA Acceptor Head requires calibration, press the ENTER key and replace the current calibrated unit with a new

Acceptor Head. To end the calibration procedure, press the Escape  key.

Calibration Error Messages

When an error occurs during a normal adjustment sequence, the Figure 6-25 screen will appear containing the following message types will appear on the screen instead of the normal adjustment message previously discussed:

- **xxxxx Communication Error xxxxx:**
Communication with WBA has failed. => Check all the connections. Make sure you have executed the correct calibration program.
- **xxxxx Adjustment Error (Gain) xxxxx:**
Gain calibration error. => Make sure you have correctly inserted White Calibration Paper as instructed by the monitor.
- **xxxxx Adjustment Error (Black Level) xxxxx:** Black level calibration error. => Make sure you have correctly inserted Black Calibration Paper as instructed by the monitor.
- **xxxxx Adjustment Error (No paper) xxxxx:** No paper level calibration error. => Make sure you have removed all calibration paper.
- **xxxxx Adjustment Error (MAG) xxxxx:** Magnetic head calibration error. => Make sure you have correctly inserted a MAG Head Test Board into the Validator as instructed by the monitor.

When calibration error occurs, the sensor signal name and the signal value involved in the error will be displayed on the line below the “The gain of the following sensors is not in ascending order” message. Figure 6-25 displays an example of a typical error message.

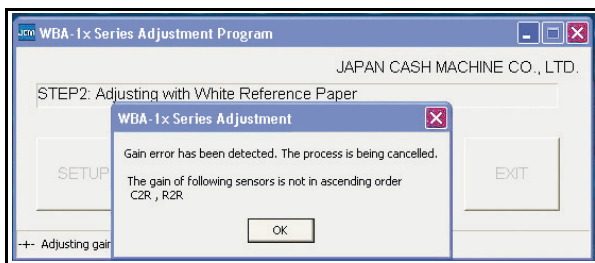

Figure 6-25 Typical Error Message Screen

Sensor Signal and Name Conversions

Table 6-1 lists the Sensor Signal Name vs. its Sensor Name comparisons for the WBA-1X-SS Validator, and Table 6-2 lists the Sensor Signal Name vs. its Sensor Name comparisons for the WBA-2X-SS Validator.

Table 6-1 WBA-1X-SS Validator Sensor Names

Signal Name	Sensor Name
C2I	HPC, LEC
R2I	HPR, LER
L2I	HPL, LEL
C2R	HPC, LEC
R2R	HPR, LER
L2R	HPL, LEL
A	PT1, LE1
B	PT2, LE2
BUR	HBAR
CDR	HPC
RDR	HPR
LDR	HPL

Table 6-2 WBA-2X-SS Validator Sensor Names

Signal Name	Sensor Name
C2I, C2R	UHPC, DHPC
CUI, CUR	UHPC
CDI, CDR	DHPC
R2I, R2R	UHPR, DHPR
RUI, RUR	UHPR
RDI, RDR	DHPR
L2I, L2R	UHPL, DHPL
R2E	PT1
L2E	PT2
R2A	PT3
L2A	PT4
BUR	HBAR

Flash Memory Download Procedure

This section describes how to download a software program to the Flash EPROM on the CPU Board.

When To Download

Download new software whenever the following conditions occur:

- When a Software Upgrade is required
- After a CPU Board has been replaced.

Refer to “Forced Download Mode” on page 9 of Appendix A for further downloading information and procedures.

WBA[®] Series

World Bill Acceptor (WBA[®]-1x/2x -SS & SS2)

Section 7

7 EXPLODED VIEWS AND PARTS LISTS

This section provides product exploded views and parts lists for the World Bill Acceptor Series (WBA). This section contains the following information:

- Entire WBA Unit View and Parts List
- Acceptor Unit View and Parts
- Transport Unit View and Parts
- Frame Unit View and Parts
- Cash Box Unit View and Parts

Entire WBA Unit View and Parts

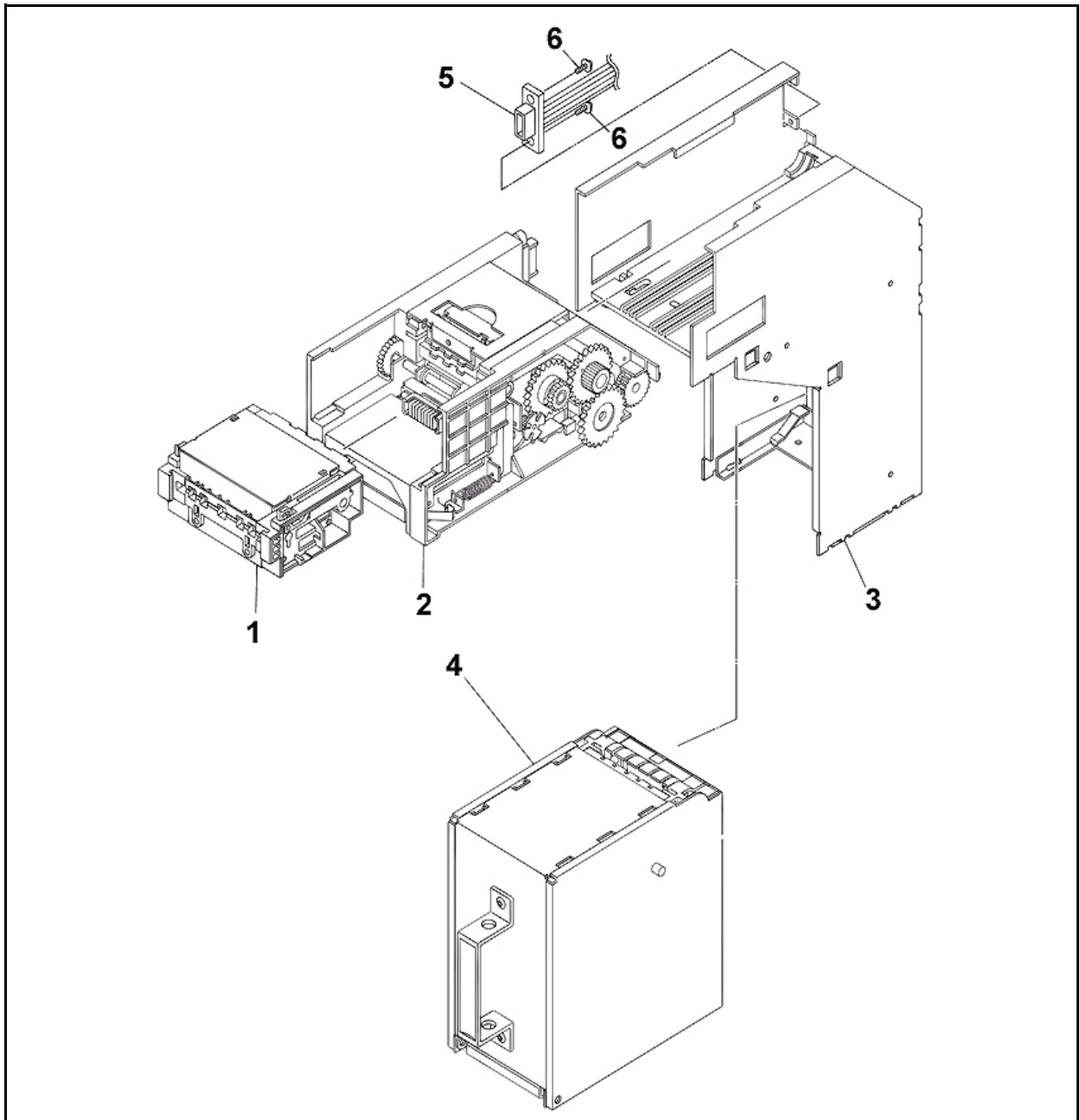

Figure 7-1 Entire WBA Unit Exploded View

Entire WBA Unit Parts List**Table 7-1** Entire WBA Unit Parts List

No.	EDP No.	JAC Part No.	Description	Remarks
1	116292		WBA-1X-SS Acceptor Unit Type 67	WBA-12/13
	077085		WBA-1X-SS Acceptor Unit Type 77	WBA-12/13
	116527		WBA-2X-SS Acceptor Unit Type 67	WBA-22/23
	116291		WBA-2X-SS Acceptor Unit Type 71	WBA-22/23
	116528		WBA-2X-SS Acceptor Unit Type 77	WBA-22/23
	116352		WBA-2X-SS Acceptor Unit Type 81	WBA-22/23
	116345		WBA-24/25-SS2 Acceptor Unit Type 82	WBA-24/25
2	119952*		WBA-12/22-SS Transfer Unit	WBA-12/22-SS
	119964*		WBA-13/23-SS Transfer Unit	WBA-13/23-SS
	102433*		WBA-24-SS2 Transfer Unit	WBA-24-SS2
	102434*		WBA-25-SS2 Transfer Unit	WBA-25-SS2
3	116294*		WBA-SS Frame Unit	WBA-12/13/22/23-SS
	116346*		WBA-SS2 Frame Unit	WBA-24/25-SS2
4	116301		WBA-SS Cash Box (OEM Blue Handle)	WBA-12/13/22/23-SS
	116531		W BA-SS Cash Box (OEM Orange Handle)	WBA-12/13/22/23-SS
	116298		WBA-SS Cash Box (Standard)	WBA-12/13/22/23-SS
	116300		WBA-SS Cash Box (JCM Handle)	WBA-12/13/22/23-SS
	116312		WBA-SS2 Cash Box (JCM Handle)	WBA-24/25-SS2
	116310		WBA-SS2 Cash Box (Standard)	WBA-24/25-SS2
5	062897*	843-05-03A	Standard Interface Harness R	
	060455*	843-05-02A	OEM Interface Harness R	
6	046996		M3 X10 Screw with Washer	

*. It is a interim EDP#. Please contact JCM headquarters before you order.

WBA 12/13 Acceptor Head Exploded Views

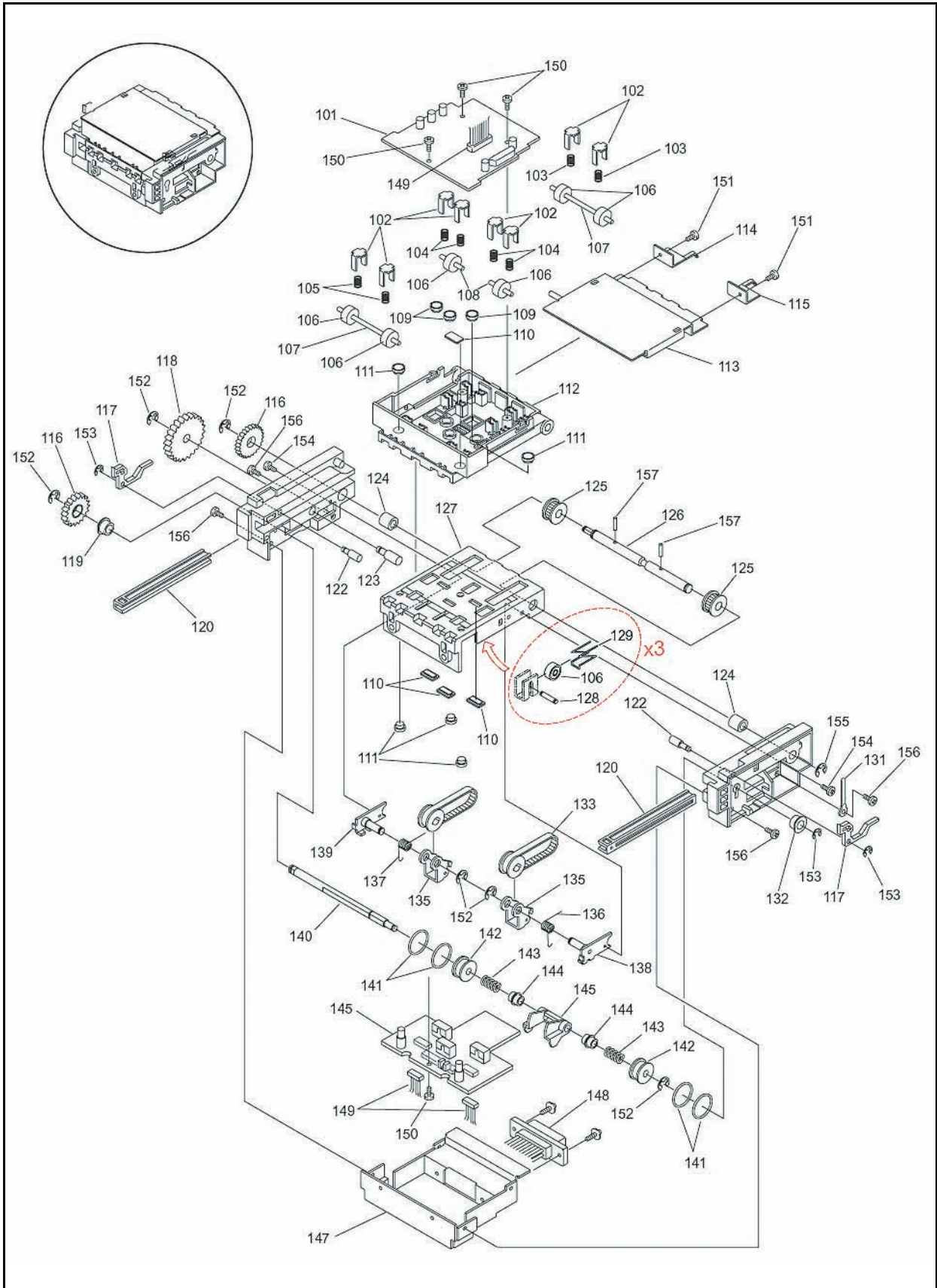

Figure 7-2 WBA 12/13 Acceptor Head Exploded View

WBA 22/23/24/25 Acceptor Head Exploded View

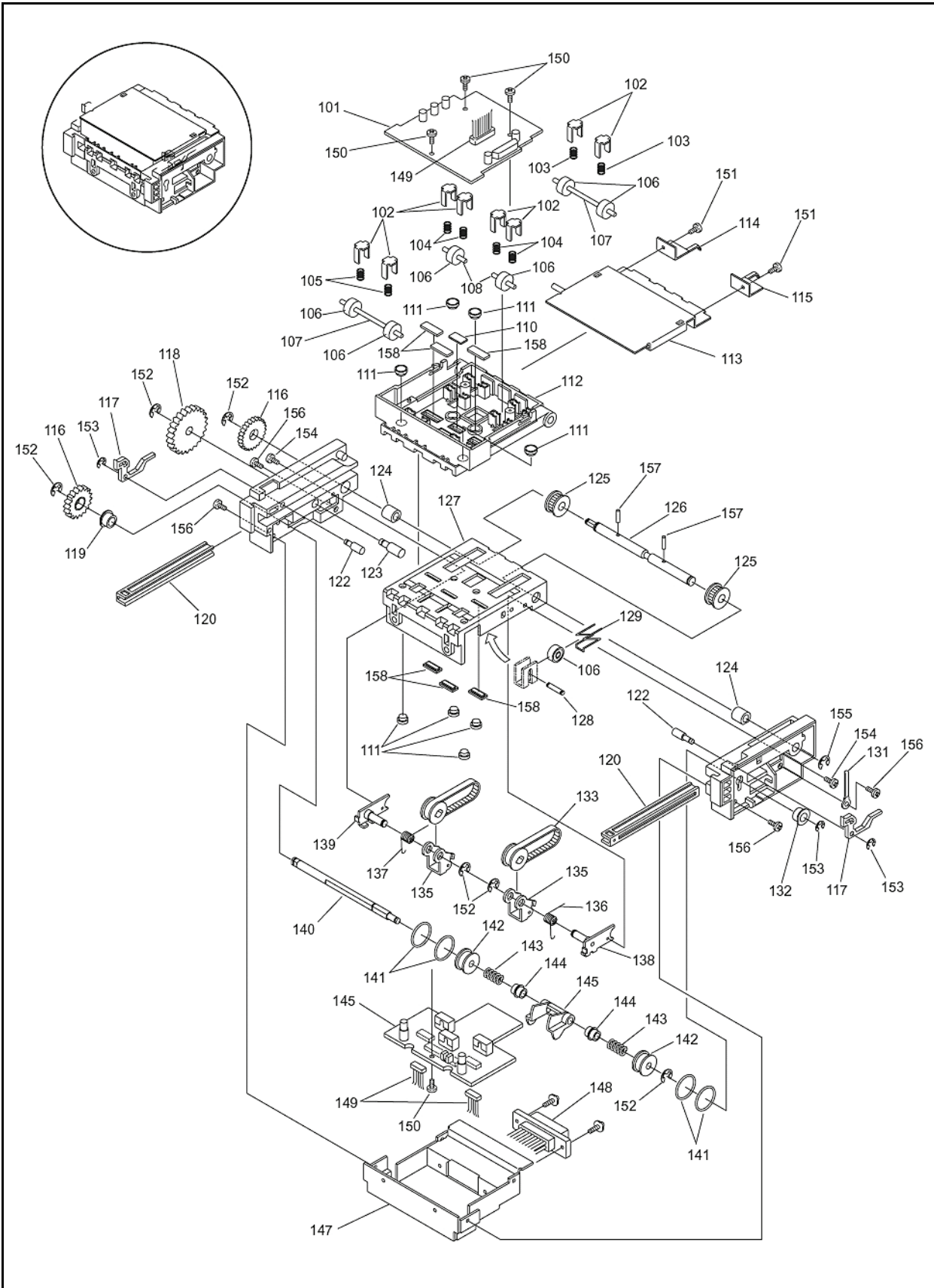

Figure 7-3 WBA 22/23/24/25 Acceptor Head Exploded View

WBA 12/13 & 22/23/24/25 Acceptor Head Collective Parts List**Table 7-2** WBA 12/13&22/23/24/25 Acceptor Head Collective Parts List

No.	EDP No.	Part No.	Description	Remarks
101	116402	943-840-06-09C-01	Upper Sensor	WBA-12/13
	116403	943-840-06-03C-01	Upper Sensor	WBA-22/23/24/25
102	052518	0943RE0118A	SP Stopper R	
103	052637	0943CS0101	TR Spring	
104	026082	CS-7V01	Head Roller Spring	
105	052639	0943CS0103	TR Spring 2	
106	052522	0943RE0126B	VH Roller R	
107	052589	0943SH0104A	P Roller Shaft L	
108	052590	0943SH0105A	P Roller Shaft S	
109	052524	0943RE0130D	Bushing (LED) R	WBA-12/13
110	052523	0943RE0129B	Bushing (RE) R	WBA-12/13
111	040342	0943RE1009	(RE-7AJ04A) Sensor Bushing	
112	052520	0943RE0124J	Guide A (MG) R	WBA-12/13
	054623	0943RE0101H	Guide A (FOT) R	WBA-22/23/24/25
113	052466	0943PT0102C	V Top Cover R	
114	053623	0943PT0109C	Earth Plate Spring L	
115	053624	0943PT0108C	Earth Plate Spring R	
116	026105	0943RE1006	(RE-7V07) Gear (1)	
117	052517	0943RE0117A	Catch R	
118	052516	0943RE0115A	Gear VH R	
119	052512	0943RE0111A	Bushing ø5 R	
120	052519	0943RE0123G	Bill Guide 67HR	
	054625	0943RE0121F	Bill Guide 71HR	
	054631	0943RE0120F	Bill Guide 77HR	
	054633	0943RE0119C	Bill Guide 81HR	
	070728	0664RE0101A	Bill Guide 82 R	
121	052506	0943RE0102D	Guide B R	
122	052593	0943ST0103A	Catch Stud	
123	052592	0943ST0101A	Gear Stud	
124	052508	0943RE0107A	Bushing A R	
125	052514	0943RE0113B	Pulley W5 A R	
126	052588	0943SH0102A	VM Shaft	WBA-12/13
	070745	0664SH0101A	VM Shaft	WBA-22/23/24/25
127	052521	0943RE0125F	Guide D (MG) R	WBA-12/13
	054624	0943RE0104E	Guide D (FOT) R	WBA-22/23/24/25
128	052591	0943SH0107A	HD Roller Shaft	
129	052657	0943KS0103E	HDR Spring	
130	052507	0943RE0103D	Guide C R	
131	045854	CS-1	Coaching Clip* P	

Table 7-2 WBA 12/13&22/23/24/25 Acceptor Head Collective Parts List (Continued)

No.	EDP No.	Part No.	Description	Remarks
132	052513	0943RE0112A	Bushing Ø3 R	
133	052585	45MXL4.8V	Timing Belt	
134	052515	0943RE0114B	Pulley W5 B R	
135	053634	0943AS0102C	Roller Guide Assy. R	
136	052635	0943KS0101B	VT Spring R	WBA-12/13
	070760	0664KS0101	VT Spring R	WBA-22/23/24/25
137	052636	0943KS0102B	VT Spring L	WBA-12/13
	070763	0664KS0102	VT Spring L	WBA-22/23/24/25
138	052464	0943AS0103D	G Fit PL R R	WBA-12/13
	070761	0664AS0102A	G Fit PL R Assy R	WBA-22/23/24/25
139	052461	0943AS0101D	G Fit PL L R	WBA-12/13
	070764	0664AS0101D	G Fit PL L Assy R	WBA-22/23/24/25
140	052587	0943SH0101A	OL Roller Shaft	
141	081620	O-Ring	P11 (EPDM70)	
142	052509	0943RE0108A	OL Roller R	
143	052638	0943CS0102	VL Spring	
144	052511	0943RE0110A	SP Collar A R	
145	052510	0943RE0109B	Lever VH R	
146	116397	943-840-06-08C-01	Lower Sensor	WBA-12/13
	116399	943-840-06-02E-01	Lower Sensor	WBA-22/23/24/25
147	052465	0943PT0101B	V Lower Cover R	
148	052676	840-05-02B	Relay Harness 2 R	
149	052677	840-05-03A	Sensor Harness R	WBA-12/13
	054618	840-05-16B	Sensor Harness R	WBA-22/23/24/25
150	055413		2.6x6 Bind P Tight	
151	023755		2.6x4 Pan W Sems Small	
152	003707		E-Ring Ø3 Sustainer	
153	003705		E-Ring Ø2 Sustainer	
154	054706		2.6x7 Pan W Sems Small	
155	003708		E-Ring Ø4 Sustainer	
156	046975		3X6 Pan W Sems Small	
157	038938		2X10 Parallel Pin	
158	040343	0943RE1008	(RE-7AJ03) Reflective Sensor	WBA-22/23/24/25

WBA Transport Unit Exploded Views (Continued)

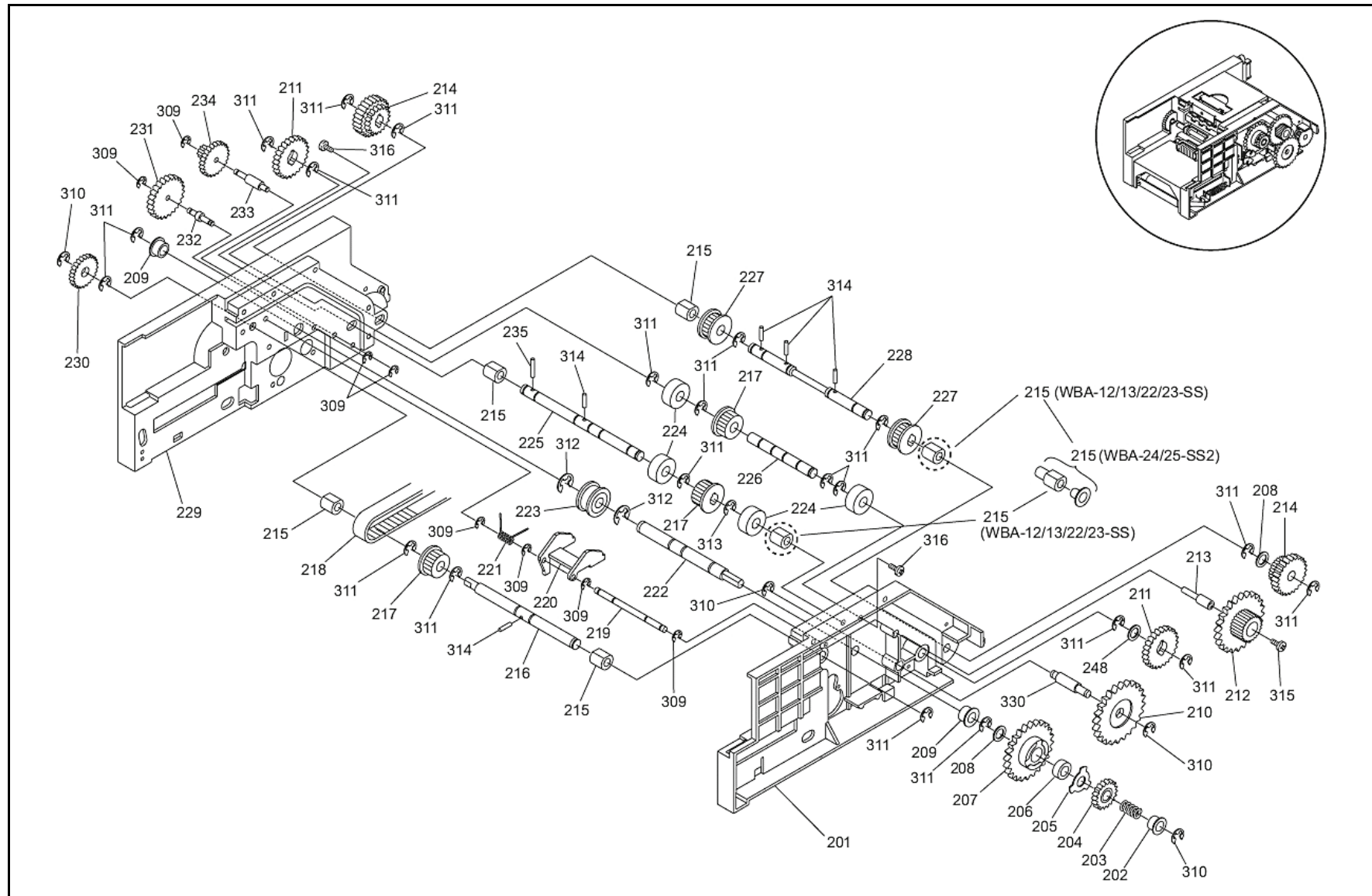

Figure 7-4 WBA Transport Unit Exploded View (Part 1)

WBA Transport Unit Exploded Views (Continued)

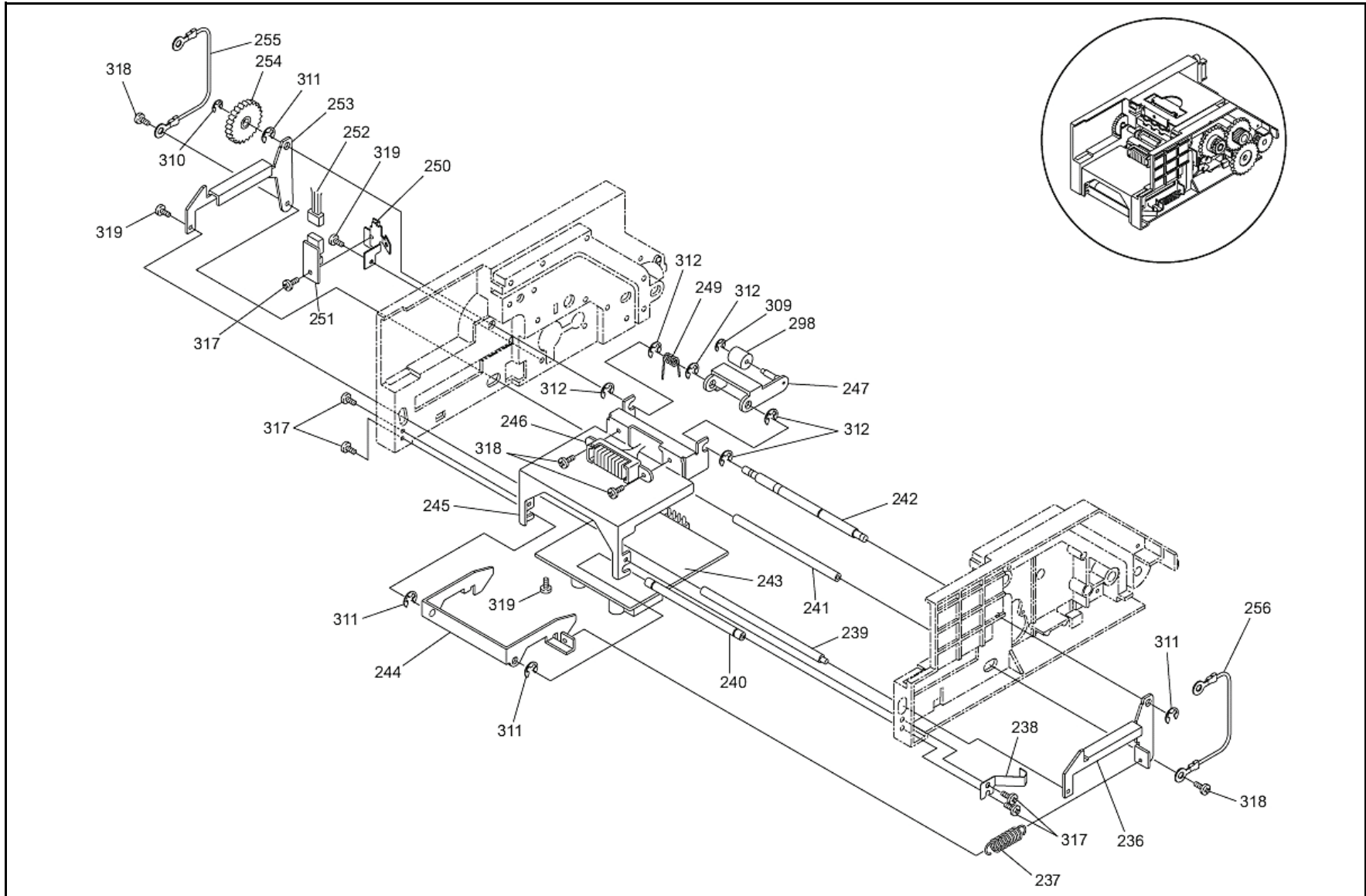

Figure 7-5 WBA Transport Unit Exploded View (Part 2)

WBA Transport Unit Exploded Views (Continued)

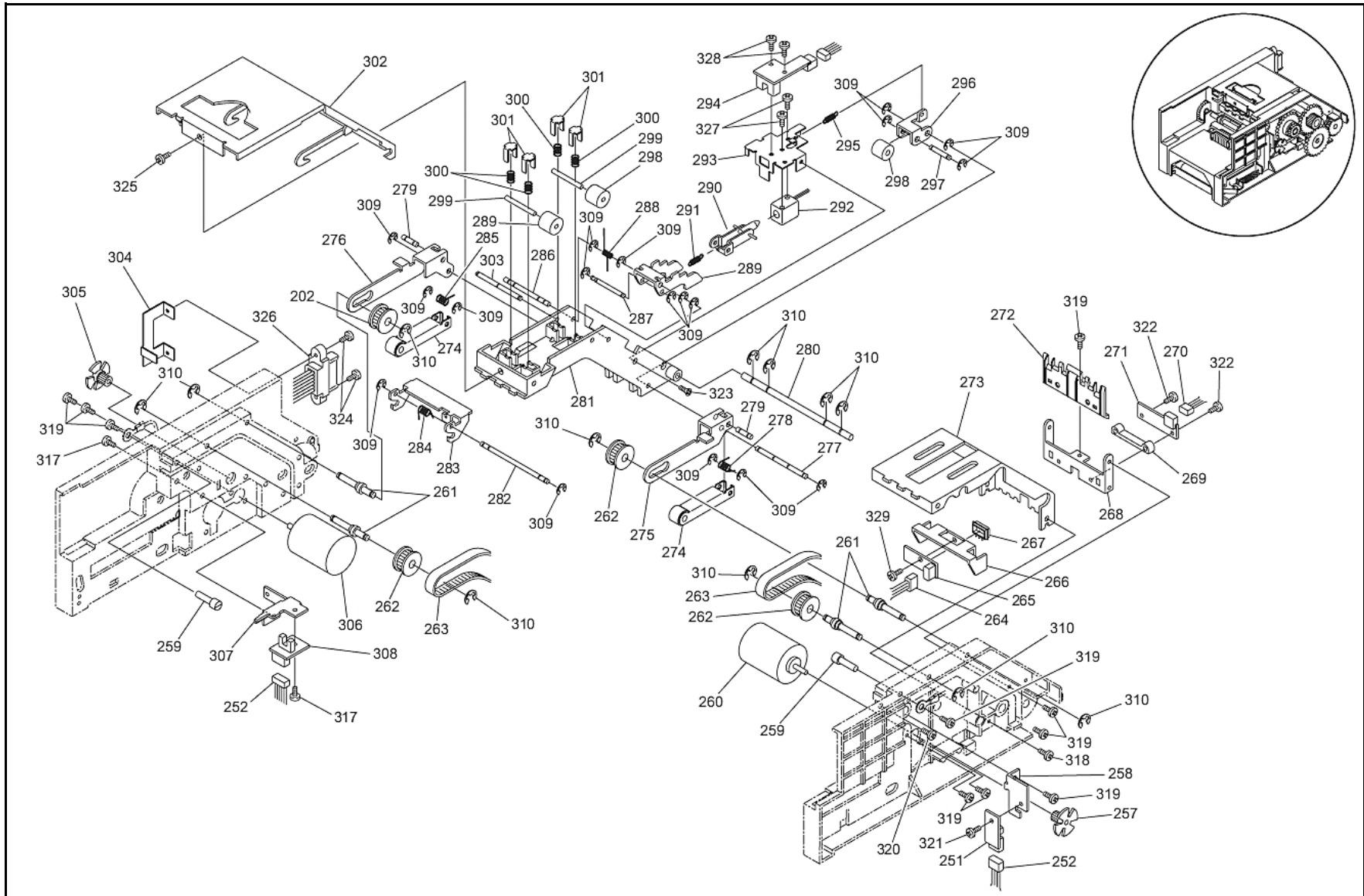

Figure 7-6 WBA Transport Unit Exploded View (Part 3)

THIS PAGE INTENTIONALLY LEFT BLANK

WBA Transport Unit Collective Parts List**Table 7-3** WBA Transport Unit Collective Parts List

No.	EDP No.	Part No.	Description	Remarks
201	053806	0943RE0226E	T Guide E Assy. R	WBA-SS
	070737	0664RE0204A	T Guide E 82	WBA-SS2
202	052533	0943RE0208B	SP Collar B R	
203	052646	0943CS0201A	G Spring	WBA-SS
	070721	0664CS0201	G Spring	WBA-SS2
204	034853	0943RE1004	(REO-08) Gear A	
205	052485	0943PT0219B	Gear W Plate	
206	092824	OWC612GXRZ	Miniature One-way Clutch	
207	092864	0943RE0230A	Gear OV (N) R	
208	052487	0943PT0221	W Plate 0.6	
209	052561	0943RE0508A	Bushing Ø6B R	
210	052538	0943RE0213B	ST Gear 2 R	WBA-SS
	070736	0664RE0203A	ST Gear 2 82 R	WBA-SS
211	052537	0943RE0212A	ST TR 2 Gear 1 R	WBA-SS
212	070735	0664RE0202A	ST TR Gear 182 R	WBA-SS2
	052536	0943RE0211B	ST Gear 1 R	
213	052615	0943ST0204G	ST Gear Stud 1	
214	052539	0943RE0214A	ST TR Gear 2 R	
215	052508	0943RE0107A	Bushing A R	WBA-SS
	070758	0664BU0202A	ST Gear Bush 2	WBA-SS2
	070727	0664RE0205A	ST Gear Bushing 3 R	WBA-SS2
216	052595	0943SH0202B	F Pulley Shaft	
217	034850	0943RE1002	(REO-05) Pulley	
218	052586	126MXL9.5V	Timing Belt	
219	052600	0943SH0207A	Shaft Fin L	
220	052545	0943RE0225B	Lever R	
221	052645	0943KS0207	Fin Spring	
222	052596	0943SH0203E	Gear Shaft	WBA-SS
	070753	0664SH0203B	Gear Shaft	WBA-SS2
223	052540	0943RE0216A	V Roller 2 R	
224	052535	0943RE0210C	T Roller R	
225	052597	0943SH0204C	Pulley Shaft 1	WBA-SS
	070754	0664SH0201B	Pulley Shaft 182	WBA-SS2
226	052612	0943BE0204C	TR Pulley Beam	
227	052514	0943RE0113B	Pulley W5 A R	
	052598	0943SH0205B	R Pulley Shaft 2	WBA-SS
	096732	0943SH0218	Pulley Shaft 2 82A	WBA-SS2
	052526	0943RE0201H	T Guide A R	WBA-SS
	070729	0664RE0201A	T Guide A 82 R	WBA-SS2

Table 7-3 WBA Transport Unit Collective Parts List (Continued)

No.	EDP No.	Part No.	Description	Remarks
228	052598	0943SH0205B	R Pulley Shaft 2	WBA-SS
	096732	0943SH0218	Pulley Shaft 2 82A	WBA-SS2
229	052526	0943RE0201H	T Guide A R	WBA-SS
	070729	0664RE0201A	T Guide A 82 R	WBA-SS2
230	026105	0943RE1006	(RE-7V07) Gear (1)	
231	052542	0943RE0219A	TR Gear 2 R	
232	059783	0943ST0209A	ST Gear Stud 3	
233	059784	0943ST0210A	ST Gear Stud 4	
234	052544	0943RE0224C	TR Gear 3 R	
235	052606	0943SH0214	Gear Pin	
236	052473	0943PT0204C	VU Catch R R	
237	052647	E-633	Spring (NO.2149)	
238	052491	0943PT0226B	SP Plate	
239	052609	0943BE0201A	V Catch Beam	
240	052610	0943BE0202B	TR Catch Beam	
241	052611	0943BE0203B	V Catch Beam 2 R	
242	052594	0943SH0201B	Catch Shaft	
243	116356	943-843-06-01A-01	CPU Board R	WBA-12/22
	116359	943-843-06-02B-01	CPU Board R	WBA-13/23
	116365	HK-664-843-06-08A-02	CPU Board R	WBA-24
	116362	HK-664-843-06-08A-01	CPU Board R	WBA-25
244	052474	0943PT0205D	TRU Catch R	
245	052467	0943AS0202E	PCB Cover Assy. R	
246	052675	840-05-01B	Relay Harness 1 R	
247	052471	0943AS0205A	VP Arm TR2 AS R	
248	052486	0943PT0220A	W Plate 0.2	WBA-SS
249	052644	0943KS0206	SVT Spring C	
250	052476	0943PT0207D	TR P Holder R	
251	052671	KI980-JCLF	ST R	
252	052680	840-05-06A	Stacker Sensor Harness 1 R	
253	052472	0943PT0203C	VU Catch L R	
254	052541	0943RE0218A	TR Gear 1 R	
255	053677	840-05-12A	FG Harness 1 R	
256	053678	840-05-13A	FG Harness 2 R	
257	052543	0943RE0222C	Gear STMO R	
258	052477	0943PT0208C	ST P Holder R	
259	096404	0943ST0203C	Catch Stud	
260	070164	943-0840-05-04-01	Transport Motor	WBA-SS
	096634	664-840-05-04B-01	Transport Motor	WBA-SS2
261	052613	0943ST0202B	Pulley Stud	

Table 7-3 WBA Transport Unit Collective Parts List (Continued)

No.	EDP No.	Part No.	Description	Remarks
262	052515	0943RE0114B	Pulley W5 B R	
263	052584	144MXL4.8V	Timing Belt	
264	052681	840-05-07A	Stacker Sensor Harness 2 R	
265	052670	KR979-JC	Stacker Sensor Circuit Board	
266	052478	0943PT0210C	F Out S Holder R	
267	052532	0943RE0207B	RE Sensor Cover R	
268	094280	4038PT0204B	B Stopper Plate S3 R	
269	052530	0943RE0205B	Spacer R	
270	120490	840-05-22	Stacker Sensor Harness 3 R	
271	120606	KI982-JC02LF	Stacker Sensor Circuit Board	
272	052664	0943RE0221F	F Out Guide R	
273	096406	0943RE0203F	T Guide C R	
274	053635	0943AS0204F	VP Arm TR AS R	
275	052489	0943PT0223B	Stopper R R	
276	052488	0943PT0222C	Stopper L R	
277	052605	0943SH0213A	PR Arm Shaft	
278	052641	0943KS0203	SVT Spring R	
279	052608	0943SH0216A	VP Arm Pin	
280	052599	0943SH0206A	TR GD Shaft	
281	096407	0943RE0204G	T Guide D R	
282	052601	0943SH0209A	C Catch Shaft	
283	052481	0943PT0215C	Cover Catch R	
284	052643	0943KS0205	TRC Spring	
285	052642	0943KS0204	SVT Spring L	
286	052603	0943SH0211B	SOL Lever Shaft	
287	052602	0943SH0210B	SOL L Shaft	
288	052640	0943KS0201	SOL Spring	
289	058120	0943PT0234B	SOL Lever 2	
290	058121	0943AS0206A	SOL Link Assy.	
291	058117	0943TS0201	Link Spring 10 GF	
292	070166	943-840-05-09B-02	(HK) Solenoid R	WBA-SS
	058206	943-840-05-09B-02	Solenoid R	WBA-SS2
293	058119	0943PT0235A	SOL Holder 2	
294	058205	KI1044-JCLF	ST R	
295	052656	E-601	Spring (NO.2069)	
296	052479	0943PT0212B	PR Arm R	
297	052604	0943SH0212A	PR Roller Pin	
298	034851	0943RE1003	(REO-06) Roller	
299	052607	0943SH0215	Roller Pin	
300	052637	0943CS0101	TR Spring	

Table 7-3 WBA Transport Unit Collective Parts List (Continued)

No.	EDP No.	Part No.	Description	Remarks
301	052518	0943RE0118A	SP Stopper R	
302	052468	0943AS0203C	TR Cover AS R	
303	058118	0943SH0217A	SOL Lever Shaft	
304	052490	0943PT0224B	CN Stopper R	
305	052534	0943RE0209C	Gear MO R	
	096635	664-840-05-05B-01	(HK) Stacker Motor R	WBA-SS
	070733	664-840-05-05B-01	Stacker Motor R	WBA-SS2
307	052480	0943PT0214B	FIN S Holder R	
308	052674	KI1102-JCLF	ST R	
309	003705		E-Ring Ø2 Sustainer	
310	003707		E-Ring Ø3 Sustainer	
311	003708		E-Ring Ø4 Sustainer	
312	003709		E-Ring Ø5 Sustainer	
313	003719	5103-21	5f Sustainer Snap Ring	
314	038938		2X10 Parallel Pin	
315	014915		2.6X5 Pan W Sems Large	
316	053008		3X6 TP Screw	
317	046975		3X6 Pan W sems Small	
318	003611		3X8 Pan W Sems Small	
319	005555		2.6X6 Pan W Sems Small	
320	055370		3X10 Pan P Tight Screw	
321	006014		3X4 Pan Head Screw	
322	005582		2.6X8 Pan Head Screw	
323	006021		2.6X4 Plate Bis Screw	
324	046996		3X10 Pan W Sems Small	
325	005332		3X5 Plate Bis Screw	
326	060436	843-05-01A	Harness R	
327	005683		2X4 Pan Sems Screw	
328	003585		2.6X4 Pan Head Screw	
329	061331		2.6X6 Pan W Sems Small	
330	052616	0943ST0205A	ST Gear Stud 2	WBA-SS
	070756	0664ST0201	ST Gear Stud 2 82	WBA-SS2

WBA Frame Unit Exploded View

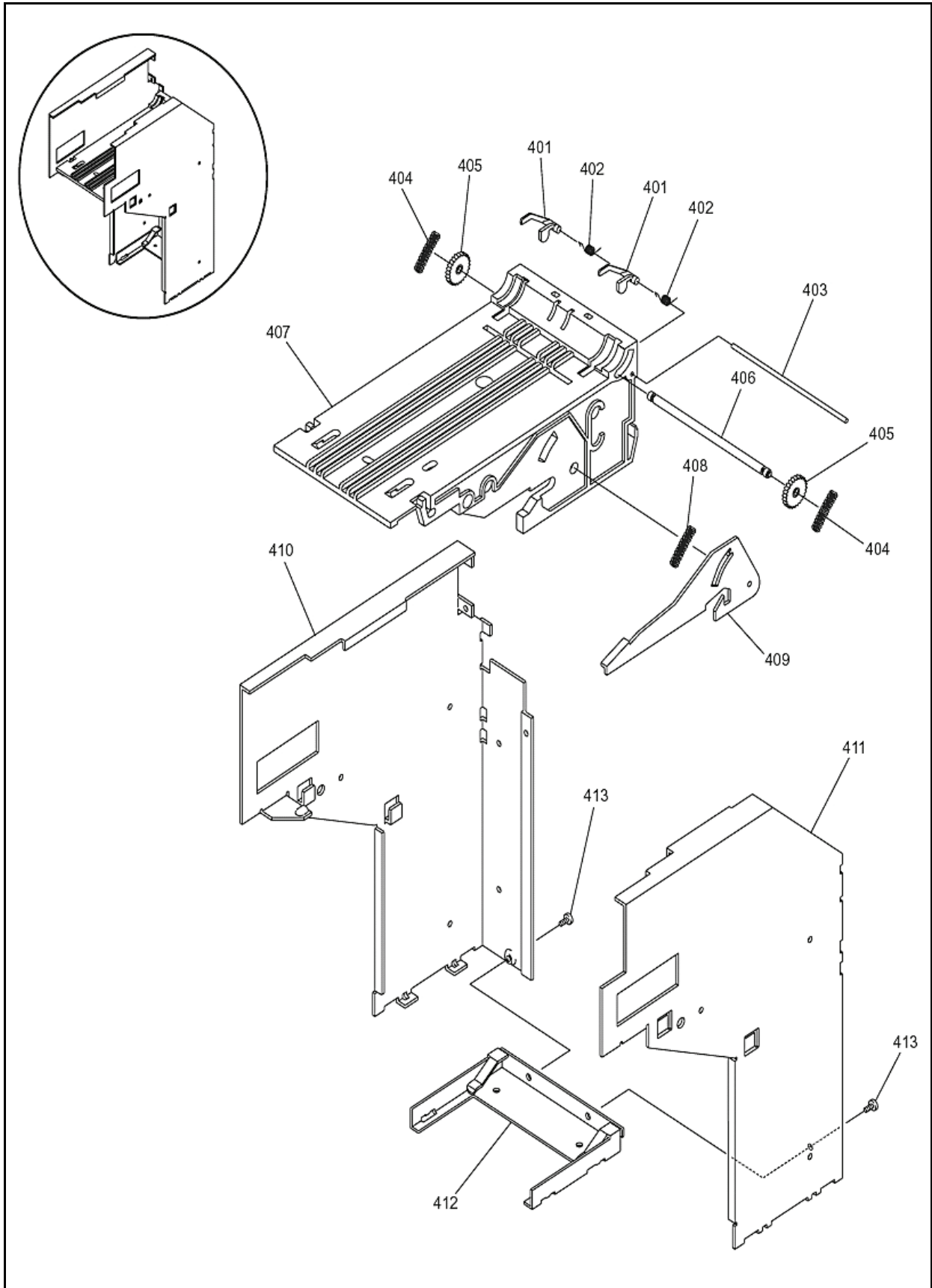

Figure 7-7 WBA Frame Unit Exploded View

WBA Frame Unit Parts List**Table 7-4** WBA Frame Unit Parts List

No.	EDP No.	Part No.	Description	Remarks
401	052548	0943RE0303C	Box Lever R	
402	052650	0943KS0301	FL Spring	
403	052621	0943SH0302B	Box Lever Shaft	
404	052648	0943CS0301A	FG Spring	
405	052547	0943RE0302B	Stand Gear R	WBA-12/13/22/23
	077566	0664AS0301A	Stand Gear 82 R	WBA-24/25
406	052620	0943SH0301A	S Gear Shaft	
407	052546	0943RE0301G	TR Stand R	WBA-12/13/22/23
	070766	0664RE0301A	TR Stand 82 R	WBA-24/25
408	052649	0943CS0302	BL Spring	
409	052492	0943AS0301G	Box Lever Assy. R	
410	052494	0943PT0302J	Right Frame R	
411	053807	0943PT0305F	Left Frame (2) R	
412	052495	0943PT0303C	Frame Base R	
413	003601		3X6 Pan Sems	

WBA Cash Box Unit Exploded View

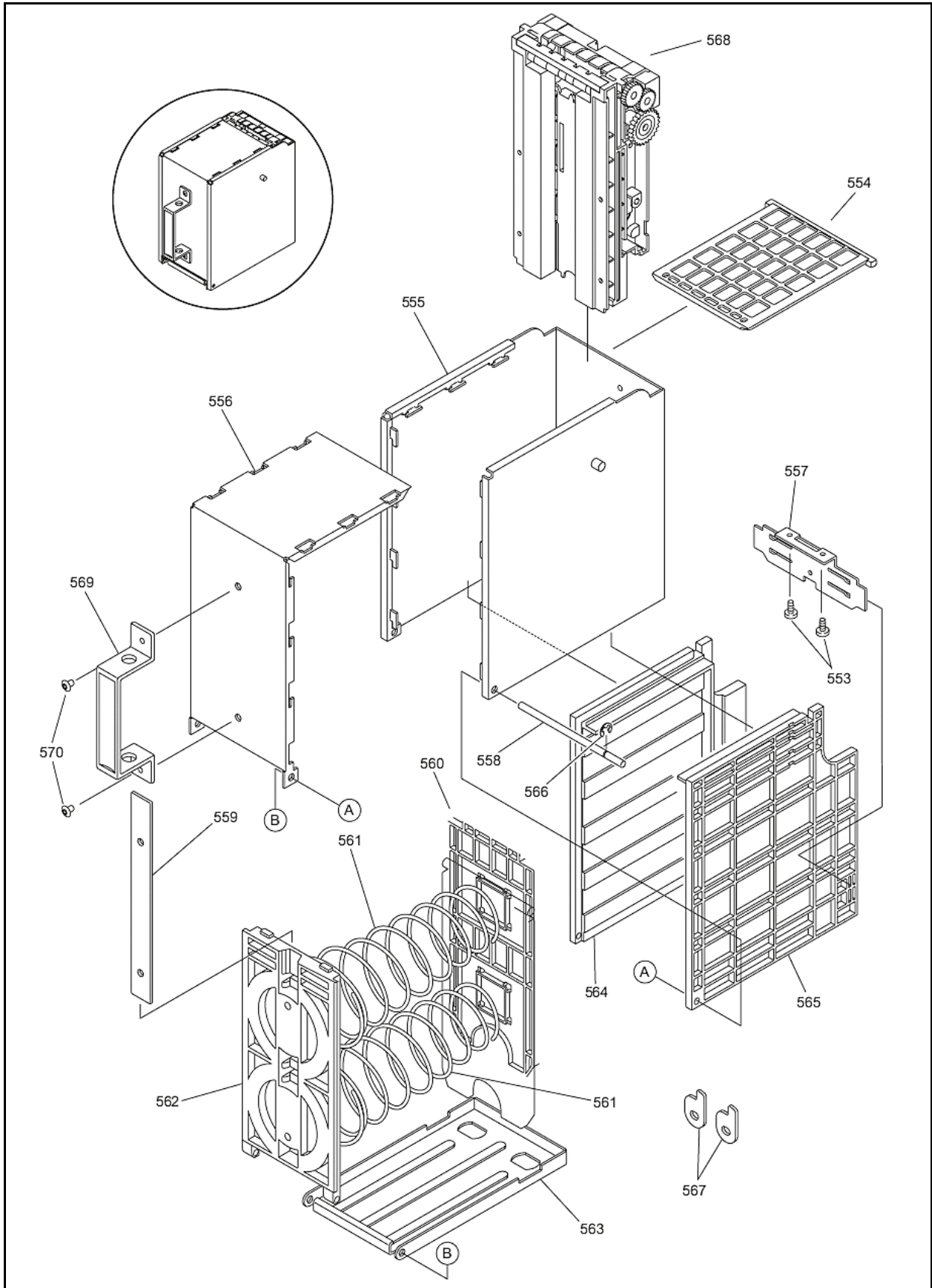

Figure 7-8 WBA Cash Box Exploded View (Part 1)

WBA Cash Box Unit Exploded View (Continued)

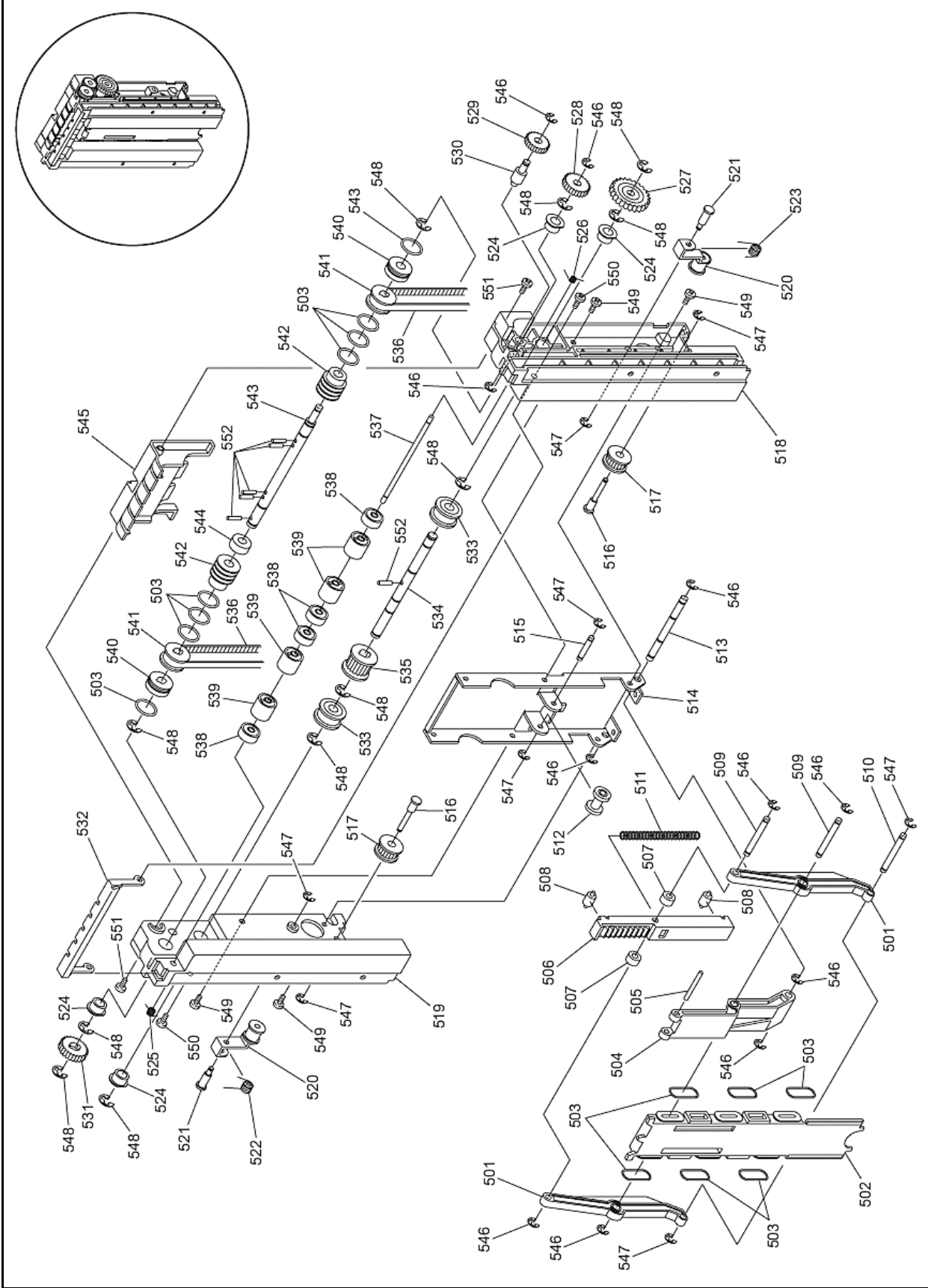

Figure 7-9 WBA Cash Box Exploded View (Part 2)

WBA Cash Box Collective Parts List**Table 7-5 WBA Cash Box Collective Parts List**

No.	EDP No.	Part No.	Description	Remarks
501	52559	0943RE0506B	Push Link 2 R	WBA-SS
	070741	0664RE0504A	Push Link 2 82 R	WBA-SS2
502	052556	0943RE0503F	Push Plate R	WBA-SS
	070740	0664RE0503B	Push Plate 82 R	WBA-SS2
503	081620		O-Ring P11 (EPDM70)	
504	052557	0943RE0504C	Pusher Link 1 R	
505	052629	0943SH0507	U Arm Pin	WBA-SS
	070749	0664SH0504	U Arm Pin 82	WBA-SS2
506	088822	0943RE0507D	PU Rack R	
507	052580	0943RE0515C	Arm Roller 1 R	
508	052631	0943BE0502A	R RO Pin	
509	052627	0943SH0505A	U R Shaft	WBA-SS
510	052630	0943SH0508A	L Arm Shaft	WBA-SS
	070750	0664SH0505	L Arm Shaft 82	WBA-SS2
511	052651	0943CS0501	PU Spring	
512	052579	0943RE0514D	R Guide Roller R	
513	052628	0943SH0506A	L Arm Shaft	
514	052503	0943PT0501E	PU Base	
515	052626	0943SH0504A	G RO Shaft	
516	052634	0943ST0504A	Pulley Stud	
517	052515	0943RE0114B	Pulley W5 B R	
518	052555	0943RE0502G	PU Guide R R	WBA-SS
	070739	0664RE0502A	PU Guide R 82 R	WBA-SS2
519	052554	0943RE0501H	PU Guide L R	WBA-SS
	070738	0664RE0501A	PU Guide L 82 R	WBA-SS2
520	053633	0943AS0501B	B VP Arm Assy. R	
521	052633	0943ST0502B	Arm Stud	
522	052653	0943KS0502	PVT Spring L	
523	052652	0943KS0501	PVT Spring R	
524	052561	0943RE0508A	Bushing Ø6B R	
525	052654	0943KS0503	PR Spring R	
526	052655	0943KS0504	PR Spring L	
527	052582	0943RE0518D	PU Gear 2 R	
528	052547	0943RE0302B	Stand Gear R	WBA-SS
529	052581	0943RE0517A	PU Gear 1 R	
530	052632	0943ST0501A	Gear Stud	
531	018184	0943RE1005	(SBC-0216) Gear (Z16)	
532	052504	0943PT0502C	PR Cover R	
533	052578	0943RE0512C	V Roller R	

Table 7-5 WBA Cash Box Collective Parts List (Continued)

No.	EDP No.	Part No.	Description	Remarks
534	052624	0943SH0502B	Shaft Gear	
	070747	0664SH0502	Shaft Gear 82	
535	052563	0943RE0510D	Rack Gear R	
536	052583	150MXL4.8V	Timing Belt	
537	052625	0943SH0503A	Roller Shaft	
538	026108	0943RE1007	(RE-7V10) Roller	
539	034851	0943RE1003	(REO-06) Roller	
540	052562	0943RE0509C	B OL Pulley R	
541	052514	0943RE0113B	Pulley W5 A R	
542	034849	0943RE1001	(REO-04) Pulley	
543	052623	0943SH0501B	Pulley Shaft	WBA-SS
	070746	0664SH0501	Pulley Shaft 82	WBA-SS2
544	052577	0943RE0511B	Pulley Collar R	
545	052558	0943RE0505I	PU Cover R	
546	003705		E-Ring Ø2 Sustainer	
547	003707		E-Ring Ø3 Sustainer	
548	003708		E-Ring Ø4 Sustainer	
549	005555		2.6X6 Pan W Sems Screw Small	
550	026071		2.6X8 Pan Tapping Screw	
551	053011		2.6X14 Pan W Sems Screw Small	
552	038938		2X10 Parallel Pin	
553	046975		3X6 Pan W Sems Small	
554	052552	0943RE0404H	Box CN Plate R	
555	052496	0943AS0401H	Box Cover Assy. R	
556	052497	0943PT0402E	Box Cover 2 R	
557	052500	0943PT0405C	Tang Catch R	
558	052622	0943SH0401B	Box Pin	
559	052499	0943PT0404A	HN Plate R	
560	052553	0943RE0405H	Receiver Plate R	
561	034869	LB-02-C	Receiver Plate Spring	
562	052551	0943RE0403I	Spring Holder R	
563	052498	0943PT0403G	Box OP Cover R	
564	052549	0943RE0401H	Box Frame L R	
565	052550	0943RE0402H	Box Frame R R	
566	003706		E-Ring 2.5 Sustainer	
567	052505	0943PT0504A	Tang B R	
568	116293		Pusher Mechanism R	WBA-SS
	116306		Pusher Mechanism R	WBA-SS2
569	056758	0943PT0701	Handle A	
570	056762	AD-SSH-64	Rivet	

WBA[®] Series

World Bill Acceptor (WBA[®]-1x/2x -SS & SS2)

Section 8

8 INDEX

<p style="text-align: center;">B</p> <hr style="width: 10%; margin: auto;"/> <p>Bill jam clearing a... 2-7</p> <p>Bill Retrieval methods for... 2-7</p> <p style="text-align: center;">C</p> <hr style="width: 10%; margin: auto;"/> <p>Cautions inventory stock enduring high temperature, high humidity or dust... 1-2</p> <p>Cleaning lenses... 2-8 methods of and equipment required for... 1-2 paths, rollers & belts... 2-8 solvent use warning... 2-8</p> <p>Closing units instructions for... 1-2</p> <p>Component Parts system & individual primary/secondary... 5-1</p> <p style="text-align: center;">D</p> <hr style="width: 10%; margin: auto;"/> <p>Dimensions 3 view drawings defining... 1-6</p> <p>DIP Switch Block side panel... 2-6</p> <p>Disassembly/Reassembly instructions for... 4-1</p> <p>Downloading software procedure for... 6-2</p> <p style="text-align: center;">E</p> <hr style="width: 10%; margin: auto;"/> <p>Exploded views illustrations of... 7-1</p> <p style="text-align: center;">F</p> <hr style="width: 10%; margin: auto;"/> <p>Faults table listings of... A-1</p> <p>Flowchart operational... 2-9</p> <p style="text-align: center;">G</p> <hr style="width: 10%; margin: auto;"/> <p>General Faults troubleshooting of... A-1</p> <p style="text-align: center;">I</p> <hr style="width: 10%; margin: auto;"/> <p>Installation steps for... 2-1</p> <p style="text-align: center;">J</p> <hr style="width: 10%; margin: auto;"/> <p>Jam warning bill insertion damaged, worn, shuffling... 1-3</p> <p style="text-align: center;">M</p> <hr style="width: 10%; margin: auto;"/> <p>Mounting holes</p>	<p>location of... 2-1</p> <p>M4 Screw maximum length of... 2-1</p> <p style="text-align: center;">N</p> <hr style="width: 10%; margin: auto;"/> <p>Navigation within manual procedure for... 1-1</p> <p style="text-align: center;">P</p> <hr style="width: 10%; margin: auto;"/> <p>Performance Testing instructions for... 6-1</p> <p>Performance Tests 6 steps of... A-4</p> <p>Pin Assignments rear panel connector... 2-3</p> <p>Precaution Symbols types of... 1-2</p> <p>Preventive Maintenance cleaning material requirements... 2-8</p> <p>Primary Features of WBA Series... 1-5</p> <p>Product Parts Lists tables of... 7-1</p> <p style="text-align: center;">S</p> <hr style="width: 10%; margin: auto;"/> <p>Safety pictographs indicating... 1-1</p> <p>Special Notes italic text highlights... 1-1</p> <p>Specifications electrical... 1-4 environmental... 1-4 model & type number... 1-2 structural... 1-4 technical... 1-4</p> <p>Steps sequential numbering of... 1-1</p> <p>Symbol definitions 3 types of... 1-2</p> <p style="text-align: center;">T</p> <hr style="width: 10%; margin: auto;"/> <p>TITO definition of acronym... 2-6</p> <p>Tool Requirements workbench & field... 6-1</p> <p style="text-align: center;">W</p> <hr style="width: 10%; margin: auto;"/> <p>Warning dropping or throwing of unit... 1-2 liquid damage... 1-2 solvent use... 2-8</p> <p>Wiring Diagrams system & individual primary part... 5-1</p> <p>World Bill Acceptor general information describing a... 1-1 photo of a... 1-1</p>
------------------------------------------------------------------------------------------------------------------------------------------------------------------------------------------------------------------------------------------------------------------------------------------------------------------------------------------------------------------------------------------------------------------------------------------------------------------------------------------------------------------------------------------------------------------------------------------------------------------------------------------------------------------------------------------------------------------------------------------------------------------------------------------------------------------------------------------------------------------------------------------------------------------------------------------------------------------------------------------------------------------------------------------------------------------------------------------------------------------------------------------------------------------------------------------------------------------------------------------------------------------------------------------------------------------------------------------------------------------------------------------------------------------------------------------------------------------------------------------------------------------------------------------------------------------------------------------------------------------------------------------------------------------------------------------------------------------------------------------------------------------------------------------------------------------	---------------------------------------------------------------------------------------------------------------------------------------------------------------------------------------------------------------------------------------------------------------------------------------------------------------------------------------------------------------------------------------------------------------------------------------------------------------------------------------------------------------------------------------------------------------------------------------------------------------------------------------------------------------------------------------------------------------------------------------------------------------------------------------------------------------------------------------------------------------------------------------------------------------------------------------------------------------------------------------------------------------------------------------------------------------------------------------------------------------------------------------------------------------------------------------------------------------------------------------------------------------------------------------------------------------------------------------------------------------------------------------------------------------------------------------------------------------------------------------------------------------------------------------------------------------------------------------------------------------------------------------------------------------------------------------------------------

THIS PAGE INTENTIONALLY LEFT BLANK

WBA® Series

World Bill Acceptor (WBA®-1x/2x -SS & SS2)

Appendix A

A TROUBLESHOOTING

This section provides Troubleshooting instructions for the World Bill Acceptor Series (WBA). This section contains the following information:

- Introduction
- Troubleshooting Overview
- Fault Table Listings
- Performance Tests
- LED Diagnostic Codes

Introduction

Most Bill Acceptor failures are due to minor causes. Before replacing any parts, make sure that all assembly and circuit board connectors are properly fitted and the harness is properly connected.

Faulty bill acceptance by the Bill Acceptor is often caused when dust or iron powder adheres to the identification sensor, magnetic sensor or Transport belt. Clean the acceptor section first, then observe the operating state of the Bill Acceptor in detail when initializing power. This observation is important in locating any failure causes and the possible

fault point. If the acceptor head has to be repaired by disassembling it, always recalibrate the sensors following a repair.

Perform all repairs by referring to the Calibration and Flash Memory Software Downloading section in the Section 7 Adjustment and Performance Test Section, and in the Section 4 Assembly/Disassembly Instructions Section.

Troubleshooting Overview

The WBA allows the operator to perform fault diagnosis by checking various fault table listings against the symptom and survey the cause(s) of any failure occurrences during the process.

After determining the cause of the failure, execute the Performance Test, perform a sensor readjustment and then repair the WBA Unit replacing any appropriate parts deemed necessary.

Fault Table Listings

Table A-1 through Table A-3 list the various possible WBA fault conditions that can occur and the necessary actions required to correct them.

Table A-1 General Fault Conditions

Symptoms/Error Messages	Possible Fault Causes	Corrective Action Required
Bill Acceptor is not working (does not accept any bills).	No external power is applied to the Bill Acceptor (+12VDC & GND)	Verify that the Power Supply +12VDC and Ground cables are connected to the appropriate pins on the main connector. NOTE: The small LED to the right of the DIP Switches indicates power available when lit.
	Wrong or inappropriate connections	Verify that all harness connectors are properly seated. Check for any bent, missing or damaged pins in the connector plugs and mating receptacles.
	Corrupted software.	Re-download the correct software. Refer to "Forced Download Mode" on page A-9 of this Section for software downloading instructions.
	CPU Board failure.	Refer to the "Performance Tests" on page A-4 of this Appendix and conduct an Initial Operation Test. If the test result is Negative (NG), replace the CPU Board.
	(For WBA-11/13 only) The EPROM is inserted backwards.	Remove the Acceptor Unit from the frame. Remove the EPROM from CPU Board and reinsert it in the correct direction.

Table A-1 General Fault Conditions (Continued)

Symptoms/Error Messages	Possible Fault Causes	Corrective Action Required
Bill jams occur often.	Drive belts are dirty or damaged.	Clean all drive belts and pressure rollers. Replace as necessary.
	A pressure roller spring is loose or missing.	Check all pressure roller springs using a finger press test. Replace as necessary.
	A foreign object is lodged in the Transport path and/or inside the Cash Box.	Clean the Transport path and remove any foreign object discovered.
	The Acceptor Unit is not properly seated all the way into the frame (the Acceptor Unit latch release levers are not locked onto the frame).	Re-seat the Acceptor Unit back into the frame so it is firmly seated all the way back into the frame so the Acceptor Unit release lever latches securely lock onto the frame.
	Bill is wider than 85 mm or narrower than 62mm (out of WBA Bill width specifications).	Use only bills widths having the correct WBA size specifications.
Low acceptance rates.	Dirt and/or stains on the rollers, belts and lenses.	Clean the Transport path. Refer to the Section 2 Cleaning/Preventive Maintenance procedure.
	The unit has been disassembled and re-calibration adjustment has not occurred following re-assembly.	Make sure to readjust the sensors after reassembling the WBA Unit. Refer to the of Section 6.
	The wrong software or an old version of the software being used.	Make sure that the programmed Flash or EPROM memory software is the latest version, and it supports the currency values and country allowing acceptance.
	Software not designed to accept current Bills	Check the particular specifications for the required Bill type acceptance, and make sure the bills will be accepted by the software loaded (i.e., check denomination/issuing year, etc.).
	Sensor lenses are loose or missing.	Sensor lenses require re-positioning. Contact JCM Technical Support.
All bills being rejected.	Incorrect software (different currency type).	Download the correct software for currency being accepted. Refer to "Forced Download Mode" on page A-9 of this Section regarding Software Downloading.
	Bills are not being accepted by the software.	Make sure the bill values required are included in the software specifications (i.e., denominations/issuing year, etc.)
	Incorrect DIP Switch settings.	Enable all denominations by setting all DIP switches to OFF.
	Bill acceptance is being inhibited by Host Controller command	Enable Bill acceptance for the required Host command.
	Upper/Lower Sensor Board failure.	Change the Upper or Lower Sensor Board with a known good board. Refer to Section 4 regarding Circuit Board Removal.
	Unit was disassembled and re-calibration did not occur following reassembly.	Recalibrate all WBA Sensors following reassembly.

Table A-1 General Fault Conditions (Continued)

Symptoms/Error Messages	Possible Fault Causes	Corrective Action Required
Motor continues to run.	Upper Guide is open.	Firmly close the guide.
	A foreign object or a jammed bill is stuck in the Transport path.	Open the Guide, remove the foreign object or jammed bill, and close the cover.
	Motor driver failure.	Refer to Table A-5 on page 5 of this Appendix and conduct a Forward/Reverse Motor Rotation Test.
Can not enter the TEST mode.	Incorrect DIP Switch settings.	Set the DIP Switch No. 8 to ON, and re-supply power to the WBA.
	CPU Board failure.	Exchange the CPU Board with a known good board. Refer to "Transport CPU Circuit Board Removal" on page 4-3 of Section 4 regarding Circuit Board Removal.

Table A-2 Adjustment Fault Conditions

Symptoms/Error Messages	Possible Fault Causes	Corrective Action Required
Can not start the ADJx0Win_e.exe program by double-clicking on its icon.	PC Operating System (OS) is not compatible.	The current Adjustment program only supports the Windows 2000/XP Operating System.
	The program files are corrupted.	Request the correct programs from JCM.
Communication Error.	Wrong or inappropriate connections	Check the PC harness connections and the related WBA interface connectors. Check for any bent, missing or damaged pins in the connector plug and receptacle.
	WBA DIP Switch settings are incorrect.	Set the WBA DIP Switches 1 to 7 OFF and Switch 8 to ON. Recycle the power supplied to the external maintenance power supply (P/N 550-100042).
	CPU Board failure.	Exchange the CPU Board with a known good one. Refer to Section 4 regarding Circuit Board Removal.
Adjustment Error.	Incorrect reference paper type.	Follow the instruction provided in the ADJx0Win_e.exe program and use the correct reference paper recommended.
	Upper/Lower Sensor Board failure.	Change the Upper or Lower Sensor Board with a known good board. Refer to Section 4 regarding Circuit Board Removal.

Table A-3 Communication Fault Conditions

Symptoms/Error Messages	Possible Fault Causes	Corrective Action Required
Cannot communicate with host.	DIP Switch settings are incorrect.	Set all DIP Switches to OFF.
	Connectors are off or loosely connected.	Firmly reconnect all of the communication connectors.
	Damaged connector pins.	Check for any bent, missing or damaged pins in the connector plugs and mating receptacles.
	CPU Board is corrupted.	Exchange the CPU Board with a known good one. Refer to "Transport CPU Circuit Board Removal" on page 4-3 of Section 4 regarding Circuit Board Removal.
	Incorrect Interface.	Verify that the correct interface between the Host machine and the Bill Acceptor is being used.

Performance Tests

The WBA is equipped with diagnostic features to aid in repair and maintenance. This portion of Appendix A describes the test procedure for use with each function using DIP Switch settings to identify the cause of a failure condition. In order to identify a failure condition's cause, the WBA has to be in the TEST mode.

To enter the TEST mode perform the following steps:

1. On the CPU Board set DS1 DIP Switches No. 1 through 7 to "OFF" and Switch No. 8 to "ON".



2. Supply the power to the WBA.
3. Check that the Red diagnostic LED blinks at a steady rate. This condition indicates the unit is now in the TEST mode.
4. Set the DIP Switches depending on the test you wish to execute according to Table A-4 through Table A-12.
5. Set DIP Switch No. 8 to "OFF" to start a particular test. When the test begins, the Red diagnostic LED will extinguish (go out). After few seconds, the Red diagnostic LED will independently turn ON & OFF depending on the test being executed.
6. To finish a test, set DIP Switch No. 8 to ON again, and turn the WBA power OFF.

 **NOTE:** If the WBA-1X does not enter diagnostic mode (i.e., The LED is constantly OFF (out) or constantly ON (lit), a CPU problem may exist. Re-flash the unit (if a WBA 10/12/14) or change the EPROM (if a WBA 11/13/15).

Choosing and Selecting Operational Tests

Set the WBA into the "Test Mode", and then set the related DIP Switches to match each operational test shown in the following Test Tables. Set DIP Switch 8 to OFF initially to start each test.



NOTE: The setting of DIP Switch 8 to ON again will interrupt a test, and restore the system to the Test Mode.

Auto Calibration Mode

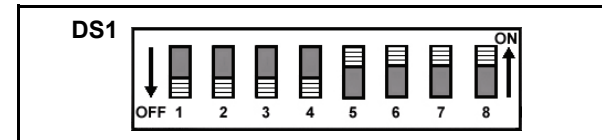

The Auto Calibration Mode is entered by turning DS1 DIP Switches 5, 6, 7 and 8, to the "ON" position and powering up the unit:

- The unit will cycle once and stop to receive the White and Black reference papers
 - Insert the calibration paper black end first
- The unit will sample the White Reference Paper then the Black Reference Paper
 - It will do this five (5) or more times and then return the calibration paper.



NOTE: The Test LED on the Power Supply or the Bezel Lamps will blink rapidly if the calibration was successful.

If calibration fails, the Test LED/Bezel Light will start to blink, then pause, blink, then pause, etc. Count the number of blinks in between pauses, this number is the error code count (see the Calibration Error Indication Table below to identify the error).



NOTE: Use calibration paper part number 501-000032 for the WBA-1X.

CALIBRATION ERROR TABLE

Table A-4 provides the Calibration Error LED Blink indications.

Table A-4 WBA-1X Calibration Error Indications

Number of LED Blinks	Description	Possible Cause
1	Entrance Lever Error	Check the PLEV/FLEV Sensor
2	Solenoid Error	Check the Solenoid in the Transport
3	Feed Sensor Error	Check the Entrance Sensor in the Transport
4	Transport Jamming	Check the Entrance Sensor in the Transport

Table A-4 WBA-1X Calibration Error Indications (Continued)

Number of LED Blinks	Description	Possible Cause
5	Gain Error (White level adjustment error)	If the reference paper was loaded correctly, change the Upper Sensor Board
6	Digital/Analog Error	If the reference paper was loaded correctly, change the Upper Sensor Board
7	Bar Sensor Error	Change the Upper Sensor Board
8	Acceptor Head Removed	Check condition of the 20 pin connector that connects head to the CPU Board
9	Magnetic Setting Error	Change the Upper Sensor Board
10	Write-in Error	Change the Upper Sensor Board
11	Black Level Error	Replace the Upper or Lower Sensor board

Diagnostic Test Mode

To enter the Diagnostic Test Mode perform the following steps:

1. Set DS1 DIP Switch No. 8 on the CPU Board to **“ON”** and DIP Switches 1 thorough 7 to **“OFF”**.
2. Apply power and observe that one of the following conditions occur:
 - The test LED/Bezel light blinks at a steady rate, indicating diagnostic mode is active

- The WBA-1X does not enter diagnostic mode
- The LED is constantly OFF (out) or ON (lit)
 - A CPU problem exists [Re-flash the unit (WBA 10/12/14) or change the EPROM (WBA 11/13/15)].

Functional Tests

Table A-5 provides a DIP Switch settings chart for performing WBA-1X Functional Tests.

Table A-5 WBA-1X/2X Functional Test DIP Switch Settings

Test No.	DIP Switch Positions								Functional Test	
	8	7	6	5	4	3	2	1		
1	E/D*								x†	Transfer Motor Forward Rotation Test (test light OFF = motor speed OK)
2	E/D							X		Transfer Motor Reverse Rotation Test (test light OFF = motor speed OK)
3	E/D					X				Stacker Motor and Pusher Mechanism Test
4	E/D				X					Acceptor Head/Stacker Test (Use Error Table A-11 only)
5	E/D				X			X		Acceptor Stacker Test without the head (Use Error Table A-11 only)
6	E/D			X						Solenoid Test
7	E/D		X							Acceptor Head Sensor Test (PH06)
8	E/D	X								Transport Sensor Test (PH07)
9	E/D					X	X	X		Bill Acceptance Test without Cash Box and Frame (Error Table A-10 or Table A-12)
10	E/D				X	X	X	X		Bill Acceptance Test with Cash Box and Frame (Error Table A-10 or Table A-12)

*. E/D = Enable/Disable

†. X = ON

Head Sensor Test (PH06)

Perform the following steps to enter the Head Sensor Test:

1. Enter diagnostic mode – DIP Switch No. 8, to **“ON”**.

2. Apply power to the WBA Unit.
3. Turn DIP Switch No. 6, **“ON”** and turn DIP Switch No. 8, **“OFF”**. This activates the Head Sensor Test. DIP Switch No. 6 will now be used as the Enable/Disable function switch for these tests.



NOTE: Use the Test LED/Bezel light to check the status of the sensor being tested; either blocked or un-blocked. The LED will lite when the signal light path of the sensor is interrupted (i.e., blocked).

Head Sensor Test DIP Switch Settings

Table A-6 provides a DIP Switch settings chart for performing the WBA-1X Head Sensor Tests.

Table A-6 WBA-1X/2X Head Sensor Test DIP Switch Setting Chart

DIP Switch Positions								WBA-10 Series Sensor Being Tested	WBA-20 Series Sensor Being Tested
8	7	6	5	4	3	2	1		
OFF		E/D*					X†	PLEV	FLEV
OFF		E/D				X		Not Used	PT3
OFF		E/D			X			PT 1 (IR, Left entrance)	PT4
OFF		E/D		X				PT 2 (IR, Right entrance)	PT1
OFF		E/D	X					HPL (Red, IR - Left Sensor)	PT3
OFF		X						HPR (Red, IR -Right Sensor)	UHPL,DHPL
OFF	X	E/D						HPC (Red, IR - Center Sensor)	UHPR,DHPR
OFF	X	E/D					X	Not Used	UHPC,DHPC

*. E/D = Enable/Disable

†. X = ON

Head Sensor Locations

Figure A-1 illustrates a top and bottom view of the WBA1x Head Sensor Locations.

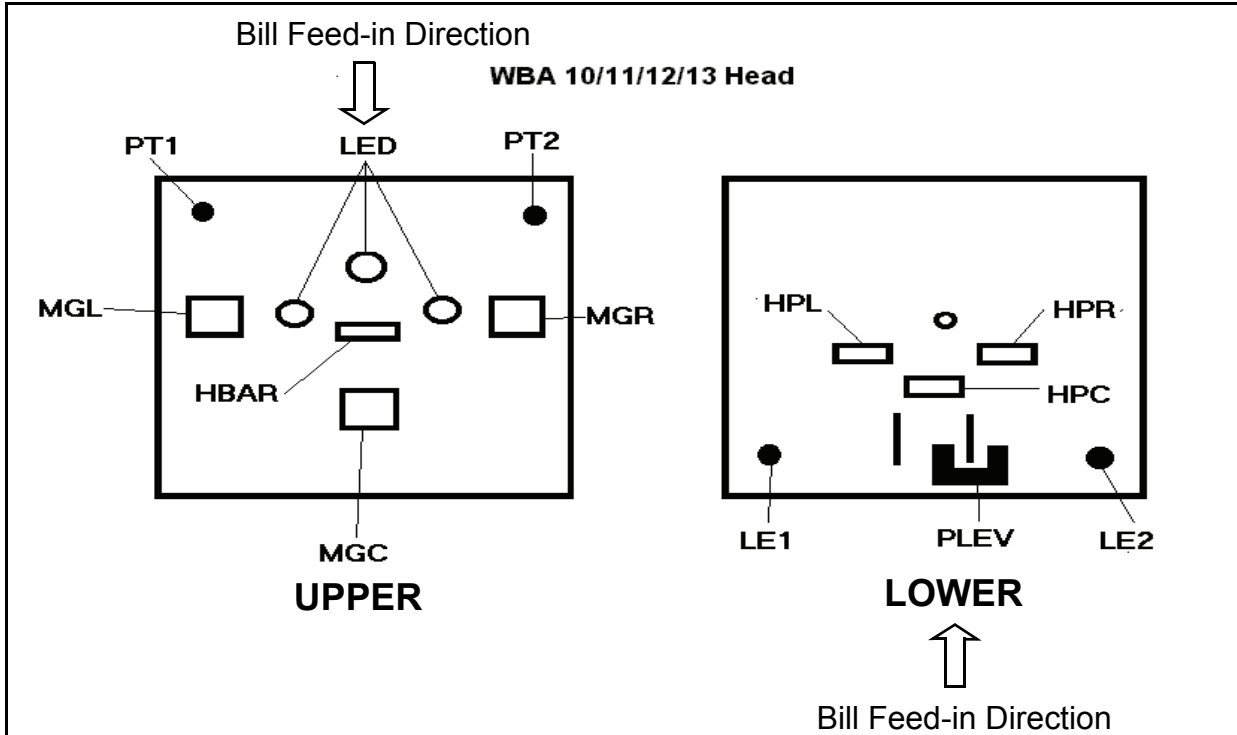

Figure A-1 WBA 1x Head Sensor Locations

Figure A-2 illustrates a top and bottom view of the WBA2X Head Sensor Locations.

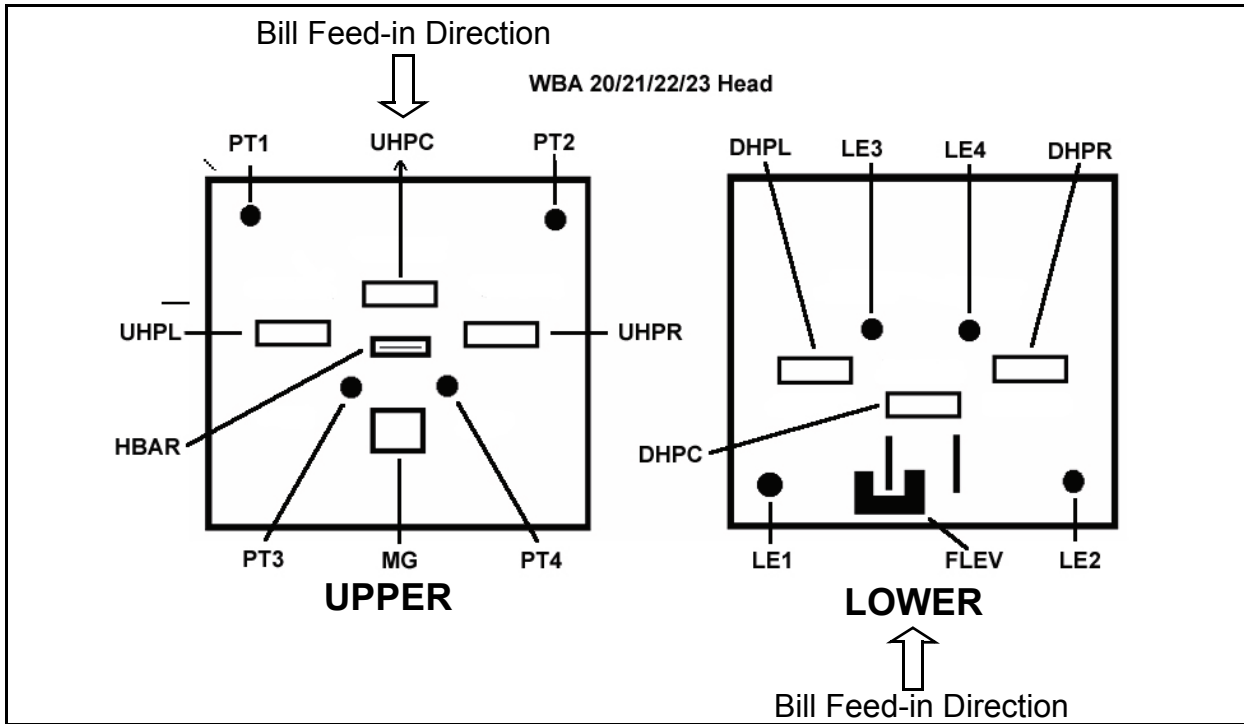

Figure A-2 WBA 2X Head Sensor Locations

Transport Sensor Test (PH07)

- Perform the following steps to enter the Transport Sensor Test:
 1. Enter diagnostic mode – DIP Switch 8, “ON” and apply power
 2. Turn DIP Switch 7, “ON” and turn DIP Switch 8, “OFF”. This activates the transport sensor test. DIP Switch No. 7 will now be



NOTE: Use the test LED/Bezel to check the status of the sensor being tested, either blocked or un-blocked. The LED will light when the light path of the sensor is interrupted (blocked).

used as the Enable/Disable Switch for these tests.

Transport Sensor Test

Table A-7 provides a DIP Switch setting chart for performing the WBA-1X/2X Transport Sensor Tests.

Table A-7 WBA-1X/2X Transport Sensor Test DIP Switch Setting Chart

DIP Switch Positions								Sensor Being Tested
8	7	6	5	4	3	2	1	
OFF	E/D*						x†	Entrance Sensor
OFF	E/D					X		Solenoid Lever Sensor
OFF	E/D				X			Feed-Out Sensor
OFF	E/D			X				Stacker Home Sensor (S1)
OFF	E/D		X					Cash Box Sensor (S2)
OFF	E/D	X						Validator Encoder Sensor
OFF	X							Stacker Encoder Sensor
OFF	E/D					X	X	Acceptor Head Detached

*. E/D = Enable/Disable

†. X = ON

Transport Sensor Locations

Figure A-3 provides the WBA-1X/2X Sensor Locations.

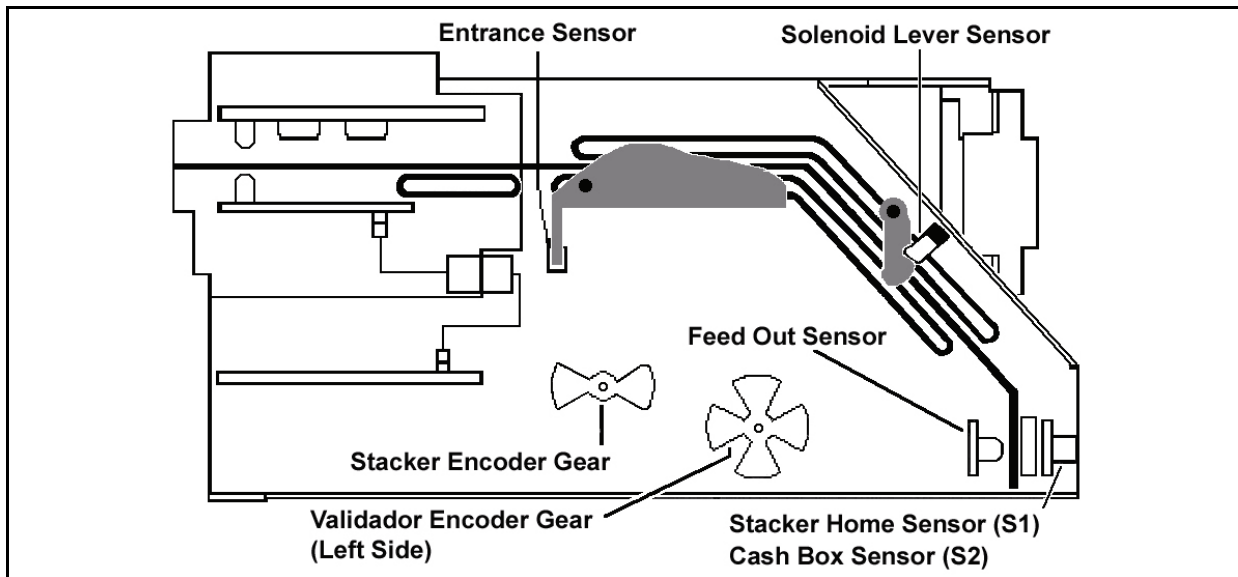

Figure A-3 WBA-1X/2X Transport Sensor Locations

Sensor, Circuit Board and Motor Locations

Figure A-4 provides the various WBA-1X/2X Sensor, Circuit Board and Drive Motor Location.

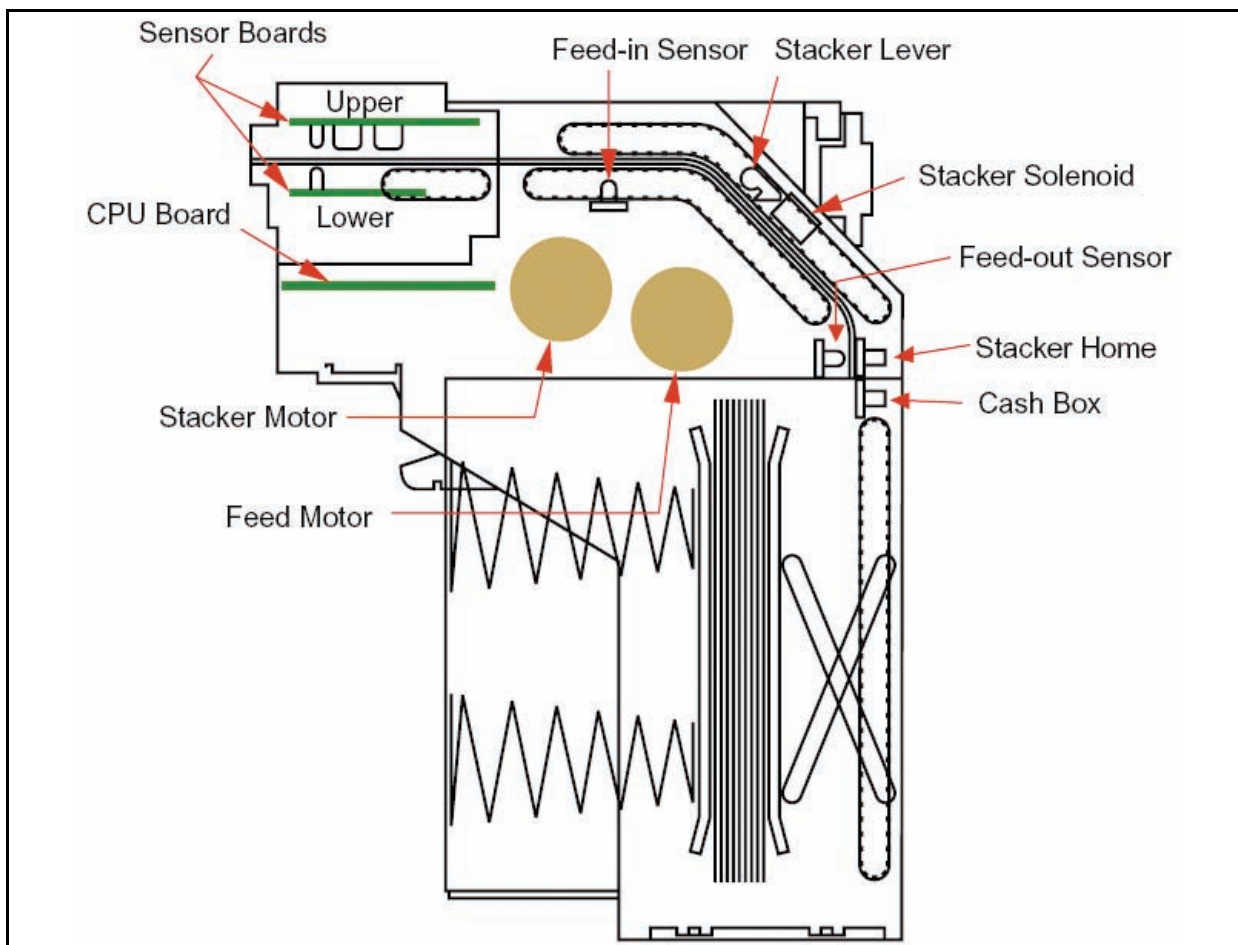

Figure A-4 WBA-1X/2X Sensor, Circuit Board and Motor Location Diagram

Bill Acceptance Test

There are two ways to run the Bill Acceptance Test:

1. With a separate head and transport.
 - The Cash Box Sensor (S2) and Stacker Home Sensor (S1) are disabled and not tested.
2. With a head and transport inserted into a frame containing a Cash Box.
 - All sensors and functions are tested.

Table A-8 provides the DIP Switch settings for performing the WBA-1X/2X Bill Acceptance Tests.

Table A-8 WBA-1X/2X Bill Acceptance Test Setting Chart

DIP Switch Positions								Bill Acceptance Test Activated
8	7	6	5	4	3	2	1	
E/D*					X	X	X†	Bill Acceptance Test without Cash Box and Frame
E/D			X	X	X	X	X	Bill Acceptance Test with Cash Box and Frame

*. E/D = Enable/Disable

†. X = ON

Bill Identification in Bill Acceptance

- Bill identification is done by counting the LED flashes after a bill is validated as follows:
 - 1 flash = \$1
 - 2 flashes = \$2 (not programmed)
 - 3 flashes = \$5
 - 4 flashes = \$10
 - 5 flashes = \$20
 - 6 flashes = \$50
 - 7 flashes = \$100
 - 8 flashes = Bar Code Ticket.

 **NOTE:** Switch #1 needs to be turned OFF after the Bill Acceptance Test has started to enable Bar Code ticket reading (ID003 Software).

Bill Acceptance Test Modes

To Enter a Bill Acceptance mode:

1. Turn DIP Switch No. 8 “ON”, apply power (diagnostic mode) and:
 - Turn the related DIP Switches ON according to the Table A-8 chart settings
 - The unit will cycle and be ready to accept and identify bills.

Forced Download Mode

Perform the following steps to initiate a Forced Download:

1. Select the appropriate download speed (see the Table A-9 Chart).
2. Connect the WBA-1X per the download tool requirement.
3. Power up the WBA-1X.

 **NOTE:** For multiple WBA-1X downloads, refer to the Multi-Download Adapter Kit Users Manual. (Part No. 701-000031R).

Table A-9 provides the DIP Switch settings for performing various WBA-1X/2X Forced Download

Table A-9 WBA-1X/2X Forced Download Mode Chart

DIP Switch Positions								Download Speed Selected
8	7	6	5	4	3	2	1	
X*	X							9,600 Baud - WBA 10 or WBA 12/14
X	X	X						19,200 Baud - WBA 10 or WBA 12/14
X	X	X					X	38,400 Baud - WBA 12/14

*.X = ON

DT-004 Downloading

Perform the following steps to initiate a DT-004 Download:

1. Connect the DT-004 (Part No. 501-000022R) to the PS15-006 power supply (Part No. 550-100042R).

- Or at game use adapter harness (Part No. 400-100068R for a WBA 10 or Part No. 400-100069R for a WBA 12).
- 2. Install the appropriate master EPROM chip into the DT-004.

 **NOTE:** The default speed for downloading a single unit is 19200 baud.

3. Connect the data harness to the WBA-1X and turn the DT-004 **"ON"**. The following conditions will occur:
 - The **Power** and **Ready** lights on the DT-004 will illuminate
 - The LEDs on the WBA-1X CPU will begin to flash alternately
4. Press **"Start"**; the **Ready** light will begin to flash indicating a download is in progress.
 - The **OK** light will then illuminate and the DT-004 will announce a beep when the download is complete
 - To verify download completion, press **Reset** and **Version**.

 **NOTE:** If the version between the EPROM and the WBA-1X verify, the **"OK"** LED will light.

DT-104 Downloading

Perform the following steps to initiate a DT-104 Download:

1. Connect the data cable to the WBA-1X.
2. Insert the proper Master EPROM into the DT-104 socket.
3. Power on the DT-104 (Part No. 701-000141R).
4. Scroll the screen to view **"SETUP"** and verify the correct download speed – change if needed.
5. Ensure multi-mode is **"OFF"**.
6. Press the Menu Button until **"Program Menu"** is displayed. One of the following conditions will occur:
 - If the CPU LED lights on the WBA-1X are alternating
 - Press **"GO"**
 - If no error **"Device Ready"** will be displayed
 - Press **"Start"**
 - The WBA-1X will show a download LED sequence on the CPU LEDs
 - The display panel on the DT-104 will count-down from the highest memory location and **"Download Successful"** will display on the panel when the download is successfully completed.

PC Downloading

Perform the following steps to initiate a PC Download:

1. Load PC Download program DOWNLOAD PROGRAM.EXE and the corresponding Validator data file into a common PC Directory (i.e., Folder).
2. Connect the Validator to a PC "Comm Port" using the 9-Pin Cable connected to the PS15-006 Power Supply.
3. Set the DIP Switches for the appropriate download speed.

4. Connect the Power Supply to the Validator.



NOTE: The two LEDs on the WBA Processor board should be alternately flashing.

5. Run DOWNLOAD PROGRAM.EXE.
6. Use the **BROWSE** function to select the program data file to be loaded into the WBA.
7. Select the download speed to match the DIP Switch setting of the WBA.
8. Press **"Start Download"**.
9. When the download is complete, **"Download Successful"** will display on the PC Screen.



NOTE: The WBA/DBV200 Download Application is available on the JCM Web Site using the Product Support/Software/Software Applications pull down menu (<http://www.jcm-american.com/products/software/apps.asp>).

Abnormal Error Code Table

Table A-10 lists the WBA-1X/2X Abnormal Operation Codes.

Table A-10 WBA-1X/2X Abnormal Operation Code Table

Abnormal Codes			
Flash Error Count	Description	Possible Cause	Follow-up Test (Refer to Table A-5)
1	Cash Box Full	Stacker Encoder	Test #3-Stacking, #7 Transport Sensors
2	Stacker Jam or Pusher Unit Trouble	Stacker Encoder or Pusher Home Sensor (S1)	Test #3-Stacking, #7 Transport Sensors
3	Transport Cover Open or Solenoid Lever Trouble	Transport Entrance Sensor or Solenoid Lever Sensor	Test #7-Transport Sensors
4	Blocked Bill Path Sensor	All Head and Transport Sensors	Test #6-Head Sensor, Test #7 Transport Sensors
5	The Acceptance Head Detached, not Calibrated or Incorrect Type	Clean and Calibrate; Check All Head Sensors and Head Detached Test	Test #6-Head Sensor, Test #7 Acceptance Head Detached
6	Transport Motor Trouble or the Signal is NOT being sent from the Encoder Sensor	Transport Motor or Transport Encoder	Test #1-Transport Motor, Test #7 Validator encoder Sensor
7	Reserved	N/A	N/A
8	Solenoid Lever Trouble	Lever Assembly, Lever Sensor	Test #5-Solenoid Test, Test #7 Solenoid Lever Sensor
10	Cash Box NOT Fully Seated	Cash Box Sensor (S2)	Test #7 Cash Box Sensor
11	Reserved	N/A	N/A
12	Reserved	N/A	N/A

Test Mode 4 Only Error Table

Table A-11 lists the WBA-1X/2X Abnormal Operation Codes.

Table A-11 WBA-1X/2X Test Mode 4 Abnormal Operation Code Table

Abnormal Codes Test Mode 4 ONLY from Table A-5			
Flash Error Count	Description	Possible Cause	Follow-up Test (Refer to Table A-5)
2	Solenoid Lever Trouble	Solenoid Sensor or Lever Jam	Test #5-Solenoid, #7 Solenoid Lever Sensor
3	Blocked Head Sensor	Clean and Calibrate Head Sensor	Test #6-Acceptor Head Sensors
4	Blocked Transport Sensor	Transport Sensors	Test #7-Transport Sensor Test
5	Cash Box Full	Stacker Encoder	Test #3-Stacker Test, #7 Stacker Encoder Sensor
6	Pusher Unit Trouble in the Cash Box	Stacker Encoder or Pusher Home Sensor	Test #7-Stacker Encoder, #7 Stacker Home Sensor
7	Acceptor Head Detached, Not Calibrated or Wrong Type	Clean and Calibrate; Check All Head Sensors and Head Detached Test	Test #6-Head Sensors, #7 Acceptor Head Detached

Return Code Error Table

Table A-12 lists the WBA-1X/2X Return Error Codes.

Table A-12 WBA-1X/2X Return Error Code Table

Return Error Codes			
Flash Error Count	Description	Possible Cause	Follow-up Test (Refer to Table A-5)
1	Crooked Insertion	Entrance Sensors	Test #6 - Entrance Sensors
2	Magnetic Pattern Error Center	Center MAG Sensor	None
3	Detected Bill in Pathway at Idle (Standby)	HPL, HPR, HPC, or Transport Entrance Sensor	Test #6 - Head Sensor, #7 Entrance
4	Data Amplitude Error (The dark-light ratio of the bill is below the fixed value)	All IR Sensors (Possible power Supply).	Test #6 - Head Sensor, #7 Transport
5	Timing Error: 1. The Bill did not reach the Sensor within the Specified Period of Time 2. The HPL HPR, did not select the bill within the specified period after it was initially drawn in. 3. The Feed-in Sensor did not detect the bill within the specified period of time following draw in.	HPL, HPR, HPC, Transport Entrance Sensor or Encoder Sensor	Test #6 - Head Sensors, #7 Transport Entrance Sensor, Validator Encoder
6	Reserved	N/A	N/A
7	Error in a Photo Sensor Level	Clean and Calibrate	Test #6 - Head Sensors, #7 Transport Sensors
8	Level Error; the Bill was unusually dirty or two overlapping Bills occurred	Entrance Sensors	Test #6 - Head Sensor
9	Return Command by DIP Switch	Check DIP Switch Settings	None
10	Return Command by the Host	Check Machine Settings	None
11	Solenoid Lever Trouble	Solenoid Lever or Solenoid Sensor	Test #5 - Solenoid Test, #7 Solenoid Sensor
12	The Sensors Detect Movement in the Wrong Direction During Bill Transfer to the Cash Box: 1. None of the HPR, HPC, or HPL detects a Bill when the type of bill signal is output. 2. The Feed-in Sensor stops detecting a Bill before the HPC Sensor during a transfer of the Bill to the Cash Box. 3. The HPC Sensor detected a bill again during transfer of a Bill to the Cash Box.	HPL, HPR, HPC, or Transport Entrance Sensor	Test #6 - Head Sensor. #7 Transport Entrance Sensor
13	The Bill is of a Length other than Specified	HPL, HPR	Test #6 - Head Sensor
14	Color Pattern Error	HPL, HPR, HPC (Red Component)	Test #6 - Head Sensors
15	Magnetic Pattern Error Left or Right	Left or Right MAG Sensor	None

WBA[®] Series

World Bill Acceptor (WBA[®]-1x/2x -SS & SS2)

Appendix B

B GLOSSARY

A

- 1 **Acceptor** – a term used in Communications Section 3 referencing functions sent to, and received from the Bill Acceptor by software commands.
- 2 **Anti-Pullback** – a method of preventing notes (bills) from being illegally removed from a validator using a string or wire to retrieve it once it has been accepted by the unit.
- 3 **Anti-Pullback Mechanism** – The rotating drum located in the rear portion of the transport to prevent a note (bill) from being retrieved by an attached string or wire.
- 4 **Automatic Centering** – a mechanism for straightening an incorrectly inserted note (bill) prior to being read by the sensors.

C

- 5 **Country Codes** – specific codes given to a country to identify its currency type.
- 6 **CPU** – acronym for Central Processing Unit.

E

- 7 **E-Clip** – a semicircular clip designed to fit into a shaft groove to retain a component in place.

D

- 8 **DIP Switch** – Dual Inline Package Switch – a printed circuit board mountable two-position slide switch package containing up to 16 individual switches.
- 9 **Downloader** – a proper name given to a specific WBA Flash EPROM programming application (i.e., UBA Downloader V1.11)

F

- 10 **Flash Memory** – electronically programmable memory integrated circuits that can be reused without requiring special erasure procedures.

I

- 11 **Intelligent Cash Box (ICB)** – an optional system which tracks gaming assets and revenues. The ICB System standardizes and simplifies the revenue drop and soft count functions, by automating the cash collection process.
- 12 **Identification Sensor** – optical sensors used for reading images on notes (bills) for comparison to recorded known image information.

M

- 13 **Magnetic Sensor** – a sensor used to detect the magnetic ink present on certain bill denominations.

P

- 14 **Photo-coupler isolation** – an LED and photo sensor combination utilized to isolate electrical signals.
- 15 **Pictographs** – small internationally recognized safety and attention symbols placed to the left of Notes, Cautions and Warnings throughout the manual.
- 16 **Pusher Mechanism** – a device used to stack received bills into the Cash Box.

R

- 17 **RS-232C Communication** – a common serial data communication standard protocol.

S

- 18 **Sensor** – a photo sensitive device and LED combination designed to detect timing and movement events.
- 19 **Solenoid** – an electro-magnetically retracting piston that mechanically moves a lever arm or other actuator within the UBA

T

- 20 **Timing Belts** – rubber belts used to transport notes (bills) inside the Validator.

W

- 21 **WBA** – acronym for World Bill Acceptor.



925 Pilot Road, Las Vegas, Nevada 89119

Office: (800) 683-7248, Tech. Support: (702) 651-3444, FAX: (702) 651-0214

E-mail: techsupport@jcm-american.com

<http://www.jcm-american.com>